



2018 plasma torches and consumables





Our value proposition

- OEM quality and consistency
- Technical and application support from OEM-qualified product specialists
- 100% satisfaction guarantee

Contents

Page	Replacement parts suitable for these product lines	System/Torch
1	ESAB PT-20AM®	PCM-100, PCM-875, PCM-1125 and ESP®-100i
3	ESAB PT-24	Precision Plasmarc®
4	ESAB PT-15/PT-15XL Nitrogen	ESP-300, ESP-400, ESP-600 and ESP-1000
5	ESAB PT-15XL Oxygen	ESP-300, ESP-400, ESP-600 and ESP-1000
6	ESAB PT-19XL	ESP-200/300/400/600C/1000, PCM-150/1500
7	ESAB PT-19XL+S	ESP-200/300/400/600C/1000, PCM-150/1500
8	ESAB PT-19XLS	ESP-200/300/400/600C/1000, PCM-150/1500
10	ESAB PT-600	ESP-200/300/400/600C/1000, PCM-150/1500
14	ESAB PT-600 and PT-19XLS heavy duty	ESP-200/300/400/600c/1000, PCM-150/1500
18	ESAB PT-36 (m³ system)	ESP-200/300/400/600C/1000, EPP-200, 360
21	CENTRICUT® ESAB Air Curtain	ESP-200/300/400/600C/1000, EPP-200, 360, PCM-150/1500
22	KALIBURN® FineLine™200	FineLine200PC and 150PC
23	KALIBURN SR-45i®	SR-45i
24	KALIBURN SR-45i Retrofit	SR-45i
26	KALIBURN Spirit I®, Spirit II®, and ProLine®	Spirit I 150a, 200a, 275a, 400a , Spirit II 150, 275, 400, ProLine 2150, 2200, 2260
28	KJELLBERG® HiFocus 100®	PerCut 101®
29	KJELLBERG HiFocus 130/160i	PerCut 160/170
30	KJELLBERG HiFocus 130/160i/161i	PerCut 210M
31	KJELLBERG HiFocus 80i/130/161i Neo	PerCut 221M
34	KJELLBERG HiFocus 280i/360i/440i	PerCut 370.1
35	KJELLBERG HiFocus 280i/360i/440i	PerCut 370.2
36	KJELLBERG HiFocus 280i/360i/440i	PerCut 450M
39	KJELLBERG HiFocus 80i/130/161i/280i/360i/440i Neo	PerCut 451M
41	KJELLBERG FineFocus 800® Plus	PB-S80
42	KJELLBERG FineFocus 800, 900, PA-S70, PA-S75	PB-S70/75/77
43	KOIKE® Super-400 Plus	Super-400 Plus
44	KOMATSU® Razor® 40 amp	Razor 40 amp
45	KOMATSU Razor 90/120 amp	Razor 90/120 amp
46	THERMAL DYNAMICS PCH/M-150	PAK 15XC, MERLIN®
47	THERMAL DYNAMICS Maximizer 300	MERLIN 3000, 6000, 6000GST

Centricut is not affiliated with the named manufacturers. Reference to machines, parts, descriptions, and model numbers are for convenience in verifying compatibility only. All parts are made by or for Centricut and are not made by the referenced manufacturers (unless expressly indicated). Centricut is a registered trademark of Hypertherm Inc. All other trademarks are the properties of their respective owners.

Plasma technology enhancements

Hypertherm® technology and quality drive superior performance of Centricut® consumables. Cut with confidence, it's Hypertherm.



SilverLine® electrode technology

- Slows wear
- Maximizes usage
- Extends electrode life

Through the use of solid state welding technology and optimized coolant flow, SilverLine technology slows the wear of hafnium, the material which produces the plasma arc, by more efficiently removing heat from the electrode. By maximizing the silver-hafnium interface and optimizing the geometry of the silver, Centricut SilverLine electrodes can be used 25 to 300% longer than other silver-copper and all-copper electrodes.

CoolFlow™ nozzle technology

- Maintains orifice shape and size
- Reduces torch leaking
- Extends nozzle life and improves cut quality

Every plasma operator will tell you that the most common nozzle failure is when the orifice goes out of round. Maintaining nozzle orifice shape and size directly impacts nozzle life and cut quality. CoolFlow technology utilizes improved cooling features and optimizes coolant flow to preserve orifice size and shape longer than any other nozzle available. O-ring placement on CoolFlow nozzles reduces torch leaking which can cause consumable and torch failure.



Backed by Hypertherm technology, product quality and world-class customer support, Centricut plasma consumables deliver reliability to your process at a lower cost.

Centricut is not affiliated with the named manufacturers. Reference to machines, parts, descriptions, and model numbers are for convenience in verifying compatibility only. All parts are made by or for Centricut and are not made by the referenced manufacturers (unless expressly indicated). Centricut is a registered trademark of Hypertherm Inc. All other trademarks are the properties of their respective owners.

Plasma technology advantage

OEM	Torch	Systems	Technology	Advantage
ESAB®	PT-36, PT-36R	M3, EPP, ESP	SilverLine® electrode	Up to 2 times life
			CoolFlow™ nozzle	Up to 2 times life
			Quick change torch	Ease of use, productivity
	PT-24	Precision Plasmarc	SilverLine® electrode	Up to 2 times life
	PT-15XL	PCM and ESP	SilverLine® electrode	Up to 2 times life
	PT-19XL	PCM and ESP	SilverLine® electrode	Up to 2 times life of XL
	PT-19XLS	PCM and ESP	SilverLine® electrode	Up to 2 times life of XL
	PT-600	PCM and ESP	Quick change torch	Ease of use, productivity
			SilverLine® electrode	Up to 2 times life of XL
Heavy duty for PT-600 and PT-19XLS	PCM and ESP	SilverLine® electrode	Up to 30% longer life	
Kaliburn®	FineLine 200	FineLine 150PC, 200PC	SilverLine® electrode	Up to 2 times life
	ProLine	ProLine 2150, 2200, 2260	SilverLine® electrode	Up to 2 times life
	Spirit	Spirit 150a, 200a, 275a, 400a	CoolFlow™ nozzle	Improved cut quality
			SilverLine® electrode	Up to 3 times Life
	Spirit II	Spirit 150, 275, 400	SilverLine® electrode	Up to 3 times Life
			CoolFlow™ nozzle	Improved cut quality
Kjellberg®	PB-S70/75/77	PA-S70,S75, FineFocus 800,900	SilverLine® electrode	Price and quality
			CoolFlow™ nozzle	Price and quality
	PerCut 210M	HiFocus 130/160i/161i	SilverLine® electrode	Price and quality
			CoolFlow™ nozzle	Price and quality
	PerCut 221M	HiFocus 80i/130/161i® Neo	SilverLine® electrode	Price and quality
			CoolFlow™ nozzle	Price and quality
	PerCut 101	HiFocus 100	SilverLine® electrode	Price and quality
	PerCut 160/170	HiFocus 130/160i	SilverLine® electrode	Price and quality
	PB-S80	FineFocus 800 Plus	SilverLine® electrode	25% longer life
			CoolFlow™ nozzle	25% longer life
	PerCut 370.1	HiFocus 280i/360i/440i	SilverLine® electrode	Price and quality
	PerCut 370.2	HiFocus 280i/360i/440i	SilverLine® electrode	25% longer life
			CoolFlow™ nozzle	25% longer life
	PerCut 450M	HiFocus 280i/360i/440i	SilverLine® electrode	Price and quality
CoolFlow™ nozzle			Price and quality	
PerCut 451M	HiFocus 80i/130/161i/280i/360i/440i® Neo	SilverLine® electrode	Price and quality	
		CoolFlow™ nozzle	Price and quality	
Koike®	Super-400 Plus	Super-400 Plus	SilverLine® electrode	Up to 1.5 times life
		CoolFlow™ nozzle	Up to 1.5 times life	
Komatsu®	Rasor 40	Rasor 40	CoolFlow™ nozzle	40% life Increase
	Rasor 90/120	Rasor 90/120	SilverLine® electrode	Up to 2 times life
CoolFlow™ nozzle			Up to 2 times life	

Centricut is not affiliated with the named manufacturers. Reference to machines, parts, descriptions, and model numbers are for convenience in verifying compatibility only. All parts are made by or for Centricut and are not made by the referenced manufacturers (unless expressly indicated). Centricut is a registered trademark of Hypertherm Inc. All other trademarks are the properties of their respective owners.

 **Centricut**[®]

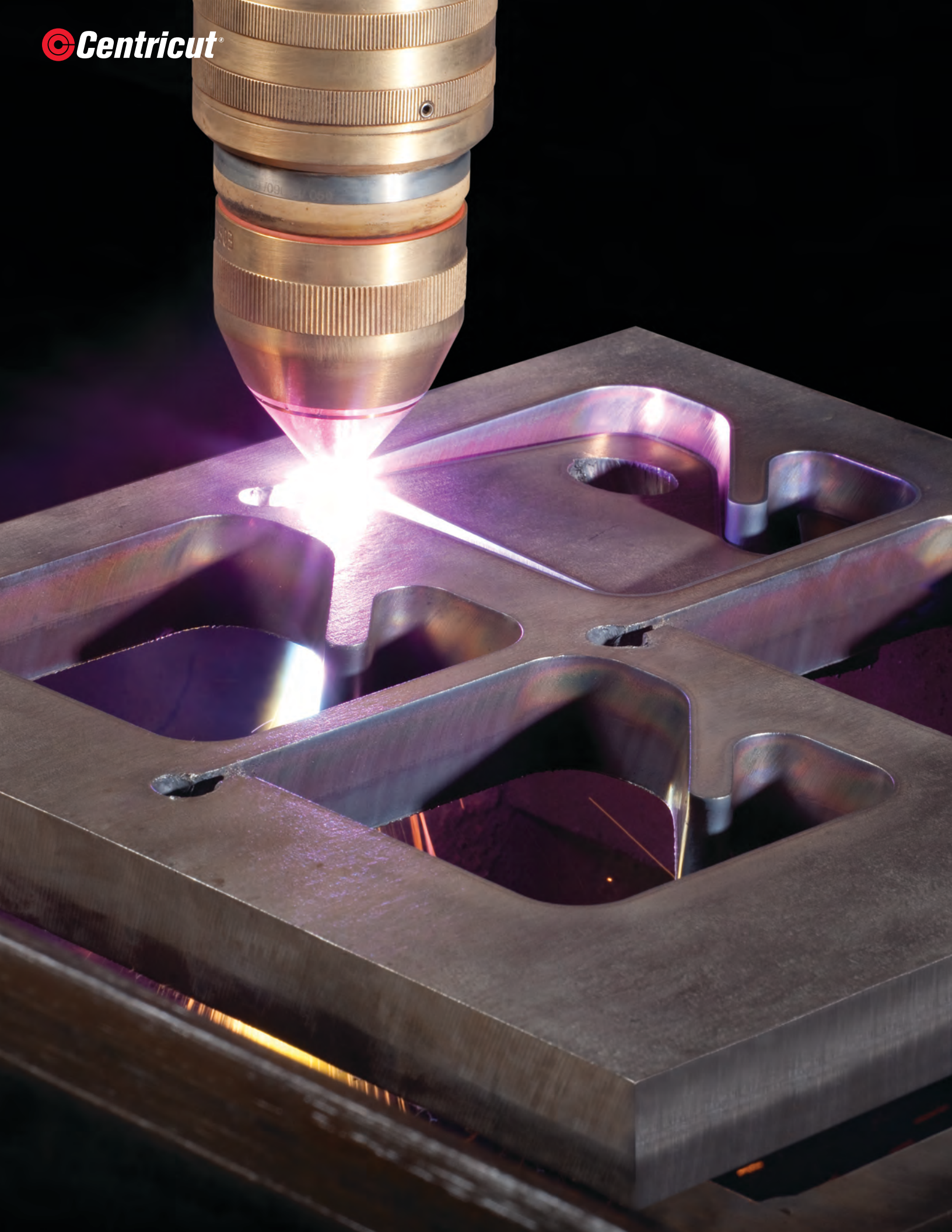

Replacement parts suitable for:
ESAB® PT-20AM®

System: PCM®-100, PCM-875, PCM-1125 and ESP®-100i

Consumables

	Centricut part number	Reference number	Description	Pkg qty
1	L39-447	21447	Heat shield, 50 amp	1
	L39-326	21326	Heat shield, 70-100 amp	1
2	C39-330*	21330	Nozzle, 50 amp	5
	C39-329*	21329	Nozzle, 70 amp	5
	C39-328*	21328	Nozzle, 100 amp	5
3	C39-150*	21150	Electrode	5
4	L39-373	21373	Insulator	1
	L39-374	21374	Baffle tube	1
5	L39-332	21332	Electrode holder assembly (includes L39-374)	1

Maintenance items

	Centricut part number	Reference number	Description	Pkg qty
6	L39-359	21359	PT-20AM torch body assembly	1
	027055	N/A	Lubricant .25 oz. (7 ml) tube	1

*Centricut part features a unique Hypertherm design that differs from the OEM design.



 **Centricut**[®]



Consumables

	Centricut part number	Reference number	Description	Pkg qty
1	C70-531*	22531	Shield, one piece with IHS tab	1
	C70-931	N/A	Shield without tab	1
2	C70-712	21712	Shield retainer insulator with o-ring	1
3	C70-010	22010	Shield cup insulator	1
4	C70-007	22007	Nozzle retainer diffuser	1
5	L70-540	21540	Nozzle A, 15 amp	1
	L70-541	21541	Nozzle B, 30 amp	1
	C70-542	21542	Nozzle C, 50 amp	5
	C70-543	21543	Nozzle D, 70 amp	5
	C70-923	21923	Nozzle E, 100 amp	5
6	L70-852	21852	Swirl baffle, 15 amp	1
	L70-536	21536	Swirl baffle, 30 amp	1
	C70-692	21692	Swirl baffle, 50-100 amp	1
7	C70-1039*	21539	SilverLine® electrode	1

Maintenance items

	Centricut part number	Reference number	Description	Pkg qty
	L70-714	950714	O-ring	1
	L70-797	638797	O-ring	5
	L70-W62	86W62	O-ring	1
8	L70-725	21725	Water baffle	1
9	L70-758	21758	Torch body	1
	Q27055	N/A	Lubricant .25 oz. (7 ml) tube	1

*Centricut part features a unique Hypertherm design that differs from the OEM design.

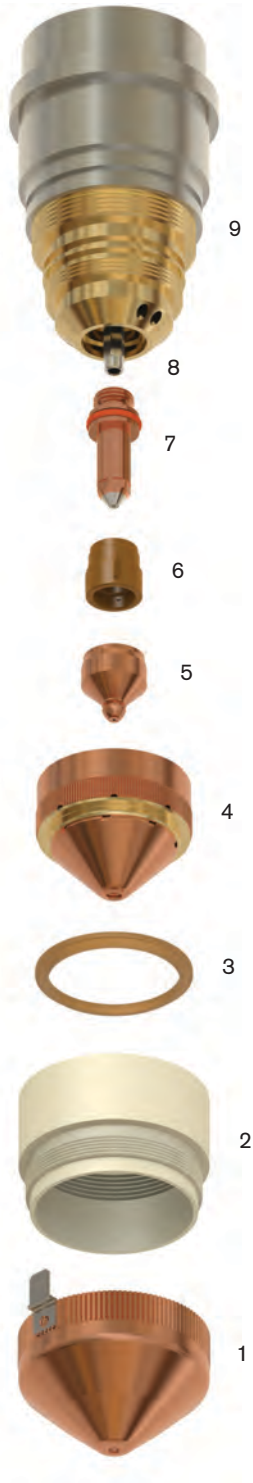

**Hypertherm technology -
SilverLine electrodes**

ESAB® PT-15®/PT-15XL® Nitrogen

System: ESP®-300, ESP-400, ESP-600 and ESP-1000

Consumables

	Centricut part number	Reference number	Description	Pkg qty
1	C10-759	20759	Nozzle retaining cap, PT-15XL	1
	C10-758	20758	Nozzle retaining cap, bevel, PT-15XL	1
2	C10-230	996230	Nozzle retaining cap, PT-15	1
	C10-691*	2075691	Nozzle assembly, N ₂ , .125, 250 amp	1
	C10-611	2075611	Nozzle assembly, N ₂ , .156, 400 amp	1
	C10-614	2075614	Nozzle assembly, N ₂ , .156, reverse swirl	1
	C10-612	2075612	Nozzle assembly, N ₂ , .200, 600 amp	1
	C10-615	2075615	Nozzle assembly, N ₂ , .200, reverse swirl	1
	C10-613	2075613	Nozzle assembly, N ₂ , .230, 750 amp	1
	C10-690	2075690	Nozzle assembly, N ₂ , .230, reverse swirl	1
	L10-587	2075587	Nozzle assembly, N ₂ , .250, 875-1000 amp	1
	C10-318	N/A	Nozzle base, 125 amp, PT-15XL	1
	C10-319	N/A	Nozzle insulator, 125 amp, PT-15XL	1
	3	C10-586	2075586	Gas baffle, ceramic, 8 x .067, 260 amp
C10-142		948142	Gas baffle, ceramic, 4 hole, 100-280 amp	1
C10-341		2075341	Gas baffle, poly, 4 hole	1
C10-360		2075360	Gas baffle, poly, reverse swirl, 4 hole	1
4	C10-236*	600236	Electrode tip, N2	5

Maintenance items

	Centricut part number	Reference number	Description	Pkg qty
5	C10-343	2075343	Electrode tip holder, N2	1
6	C10-940	21940	Contact ring assembly	1
	C10-403	20403	PA bus insulator	1
7	C10-755	20755	Insulator body with o-ring, PT-15XL	1
	C10-232	996232	Insulator body with o-ring, PT-15	1
8	C10-754	20754	Torch body, PT-15XL	1
	C10-483	19483	Double threaded mounting tube	1
	C10-932	N/A	O-ring kit, insulator body	1
	L47-110	37110	Electrode holder - removal tool	1
	O27055	N/A	Lubricant .25 oz. (7 ml) tube	1

*Centricut part features a unique Hypertherm design that differs from the OEM design.



Consumables

	Centricut part number	Reference number	Description	Pkg qty
1	C10-758	20758	Nozzle retaining cap, bevel, PT-15XL	1
2	C10-759	20759	Nozzle retaining cap, PT-15XL	1
	C10-262	21962	Nozzle, 300 amp, bevel	1
	C10-063	21963	Nozzle, 300 amp, reverse bevel	1
	C10-317	37317	Nozzle, 125 amp, PT-15XL (use with C10-142 and C10-1066)	1
	C10-318	N/A	Nozzle base, 125 amp, PT-15XL	1
	C10-319	N/A	Nozzle insulator, 125 amp, PT-15XL	1
3	C10-751	20751	Nozzle, O ₂ , 260 amp	1
	C10-962	35662	Nozzle, O ₂ , 300 amp	1
	C10-664	35664	Nozzle, O ₂ , 340-360 amp	1
	C10-665	35665	Nozzle, O ₂ , 340-360 amp, reverse	1
4	C10-1063*	20763	SilverLine® electrode, 260 amp	1
	C47-1096*	34086	SilverLine electrode, 50-250 amp, bevel	1
5	C10-1066*	35666	SilverLine electrode, 300-360 amp	1
7	C10-586	2075586	Gas baffle, ceramic, 8 x .067, 260 amp	1
	C10-142	948142	Gas baffle, 4 x .032, 50-200 amp	1
	L47-143	948143	Gas baffle, 4 x .032, 50-200 amp, reverse	1
	C10-660	35660	Gas baffle, 8 hole, standard, 300-600 amp	1
	C122-530R	0558002530R, 35661	Gas baffle, 8 x .047, 250-600 amp, reverse	1

Maintenance items

	Centricut part number	Reference number	Description	Pkg qty
6	C10-398	20398	Electrode holder, O ₂	1
	C47-084	34084	Electrode holder, bevel	1
	C10-403	20403	PA bus insulator	1
8	C10-940	21940	Contact ring assembly	1
9	C10-755	20755	Insulator body with o-ring kit	1
	C10-242	996242	Locating pin	1
10	C10-754	20754	Torch body	1
	C10-483	19483	Double threaded mounting tube	1
	C10-932	N/A	O-ring kit, insulator body	1
	L10-630	999630	Electrode holder removal tool	1
	C10-W99	86W99	O-ring, electrode holder	5
	C10-W85	86W85	O-ring, insulator body, center	5
	C10-526	996526	O-ring, insulator body, small	5
	C10-527	996527	O-ring, inside insulator body, front	5
	C10-528	996528	O-ring, outside insulator body and torch	5
	C10-106	2064106	O-ring, insulator body, rear edge, red	5
	L47-110	37110	Electrode holder - removal tool	1
	Q27055	N/A	Lubricant .25 oz. (7 ml) tube	1
	L10-4775	34775	Power cable, 4.5 ft.	1
	Q27055	N/A	Lubricant .25 oz. (7 ml) tube	1

*Centricut part features a unique Hypertherm design that differs from the OEM design.

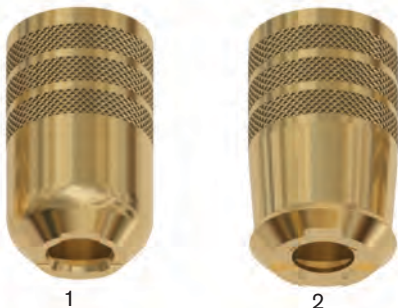

Hypertherm technology – SilverLine electrodes

System: ESP®-200/300/400/600C/1000, PCM®-150/1500

Consumables

	Centricut part number	Reference number	Description	Pkg qty
1	C47-186	948186	Heat shield, std, 100-360 amp	1
2	L47-982	21982	Nozzle retaining cap	1
3	C47-026	22026	Nozzle tip, .041, 50 amp	1
4	C47-029	22029	Nozzle tip, .071, 100 amp	1
	C47-030	22030	Nozzle tip, .082, 150 amp	1
	C47-031	22031	Nozzle tip, .091, 200 amp	1
	C47-922	22032	Nozzle tip, 250 amp	1
	C47-985	22034	Nozzle tip, 360 amp	1
	C47-995	22033	Nozzle tip, 400 amp	1
5	C47-822	21822	Nozzle, .099, 250 amp	1
	C47-885	35885	Nozzle, .120, 360 amp	1
	C47-195	22195	Nozzle, .130, 400 amp	1
	C47-027	22027	Nozzle base, 50 amp	1
6	C47-028	22028	Nozzle base, 100-400 amp	1
7	C47-1096*	34086	SilverLine® electrode, 250 amp	1
8	C47-1086*	35886	SilverLine electrode, 360 amp	1
	C47-996	34086	Electrode, CopperLine®, 250 amp	1
9	C47-084	34084	Electrode holder	1
10	C47-142	948142	Gas swirl baffle, 4 hole, standard, 100-280 amp	1
	L47-143	948143	Gas baffle, 4 x .032, 50-200 amp, reverse	1
	C47-586	2075586	Gas swirl baffle, 8 hole, standard, 260 amp	1
11	C10-660	35660	Gas swirl baffle, 8 hole, standard, 300-600 amp	1

Maintenance items

	Centricut part number	Reference number	Description	Pkg qty
12	C47-940	21940	Contact ring assembly	1
	C10-403	20403	PA bus insulator	1
13	C47-434	20434	Insulator assembly	1
14	C47-391*	20391	PT-19XL torch body	1
	L47-110	37110	Electrode holder - removal tool	1
	C10-W99	86W99	O-ring, electrode holder	5
	C47-528	996528	O-ring, outside insulator body and torch	5
	C47-999	N/A	O-ring kit, insulator body	1
	C10-106	2064106	O-ring, insulator body rear edge, red	5
	C47-W85	86W85	O-ring, insulator body center	5
	C47-526	996526	O-ring, insulator body small	5
	C10-483	19483	Double threaded mounting tube	1
	C47-006	181W89	O-ring, nozzle	5
	027055	N/A	Lubricant .25 oz. (7 ml) tube	1

*Centricut part features a unique Hypertherm design that differs from the OEM design.

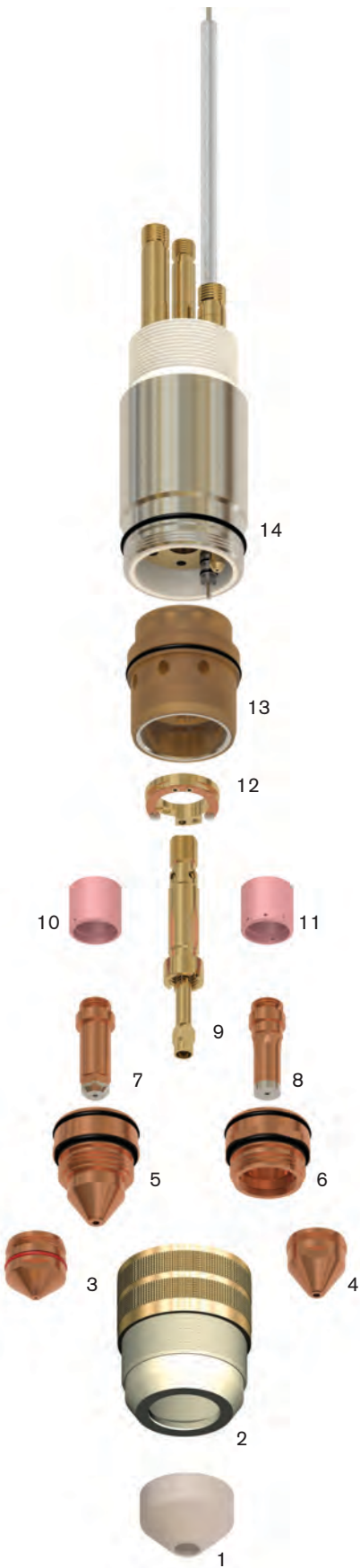

**Hypertherm technology -
 SilverLine electrodes**

Centricut is not affiliated with the named manufacturers. Reference to machines, parts, descriptions, and model numbers are for convenience in verifying compatibility only. All parts are made by or for Centricut and are not made by the referenced manufacturers (unless expressly indicated). Centricut is a registered trademark of Hypertherm Inc. All other trademarks are the properties of their respective owners.

Consumables



	Centricut part number	Reference number	Description	Pkg qty
1	L47-801	21801	Shield retainer assembly	1
2	L47-795	21795	Shield, 50 amp	5
3	C47-802	21802	Shield, 100-250 amp	1
	C47-945	21945	Shield, 300-400 amp	1
4	L47-796	21796	Diffuser, 50 amp	1
5	C47-944	21944	Diffuser, 100-600 amp	1
6	L47-982	21982	Nozzle retaining cap	1

See PT-19XL (page 6) for remaining consumables for the PT-19XL+S.

Consumables

	Centricut part number	Reference number	Description	Pkg qty
1	C47-081	37081	Shield retainer, copper	1
	C122-395	0558009395	Shield retainer, insulated, std	1
2	L47-795	21795	Shield, 50 amp	5
3	C47-802	21802	Shield, 100-250 amp	1
	C47-945	21945	Shield, 325-600 amp	1
4	L47-796	21796	Diffuser, 50 amp	1
5	C47-944	21944	Diffuser, 100-600 amp	1
	C47-496	22496	Diffuser, 100-600 amp, reverse	1
6	C122-082	N/A	Nozzle retaining cap, quick-change	1
7	C47-082	37082	Nozzle retaining cap	1
	L47-431	37431	Nozzle retaining cap, air curtain	1
8	C47-026	22026	Nozzle tip, .041, 50 amp	1
9	C47-029	22029	Nozzle tip, .071, 100 amp	1
	C47-030	22030	Nozzle tip, .082, 150 amp	1
	C47-031	22031	Nozzle tip, .091, 200 amp	1
	C47-922	22032	Nozzle tip, 250 amp	1
	C47-985	22034	Nozzle tip, 360 amp	1
	C47-995	22033	Nozzle tip, 400 amp	1
10	C47-027	22027	Nozzle base, 50 amp	1
11	C47-028	22028	Nozzle base, 100-400 amp	1
12	C47-822	21822	Nozzle, .099, 250 amp	1
	C47-885	35885	Nozzle, .120, 360 amp	1
	C47-195	22195	Nozzle, .130, 400 amp	1
13	C47-1096*	34086	SilverLine® electrode, 50-250 amp	1
14	C47-1086*	35886	SilverLine electrode, 360 amp	1
	C47-996	34086	Electrode, CopperLine®, 250 amp	1
	L47-403	22403	Electrode, N ₂ /ArH ₂ , 600 amp	5

*Centricut part features a unique Hypertherm design that differs from the OEM design.



Hypertherm technology –
 SilverLine electrodes

Centricut is not affiliated with the named manufacturers. Reference to machines, parts, descriptions, and model numbers are for convenience in verifying compatibility only. All parts are made by or for Centricut and are not made by the referenced manufacturers (unless expressly indicated). Centricut is a registered trademark of Hypertherm Inc. All other trademarks are the properties of their respective owners.

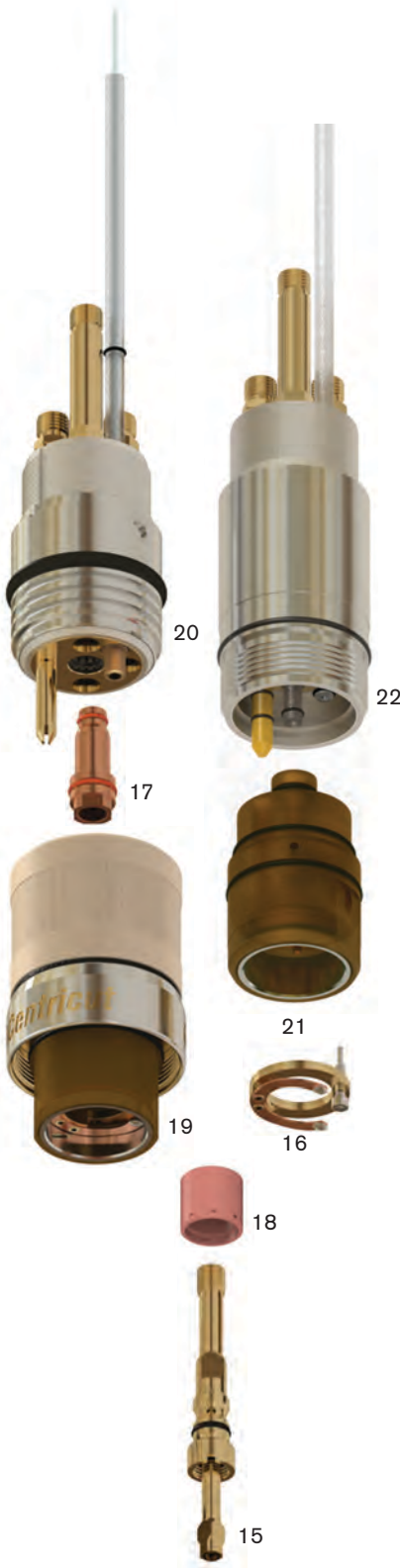
Maintenance items

	Centricut part number	Reference number	Description	Pkg qty
	C10-483	19483	Double threaded mounting tube	1
15	C47-068	37068	Electrode holder	1
16	C47-071	37071	Contact ring assembly	1
17	C96-042	N/A	Electrode holder mounting nut, PT-600	1
18	C47-142	948142	Gas baffle, 4 x .032, 50-200 amp	1
	L47-143	948143	Gas baffle, 4 x .032, 50-200 amp, reverse	1
	C10-660	35660	Gas baffle, 8 X .047, 250-600 amp	1
	L47-194	22194	Gas baffle, 32 X .023, 400 amp	1
	C122-530R	0558002530R, 35661	Gas baffle, 8 x .047, 250-600 amp, reverse	1
19	C122-8050	0558001825	Torch head, quick-change	1
20	C96-6000	0558001825	Torch base, quick-change, PT-600	1
	C96-6100	0558001825	Torch kit, quick-change, PT-600	1
21	C47-083	37083	Insulator body	1
22	C47-066	37066	Torch body	1
	C122-081	N/A	I H S wire assembly kit	1
	C122-088	N/A	Bullet plug kit, quick-change torch	1
	C122-850	N/A	Air curtain kit, QC torch, std	1
	C122-391	N/A	Air curtain body, std/XC	1
	C122-106	N/A	Coupler, air curtain	1
	C122-107	N/A	O-ring kit, air curtain	1
	C47-900	N/A	Insulating tube kit, PT-19XLS/PT-600	1
	C122-072	N/A	O-ring kit, bullet plugs	1
	C122-073	N/A	O-ring kit, mounting nut	1
	C122-087	N/A	O-ring kit, retaining cap	1
	C10-033	951000	O-ring, PTFE* tubes	5
	C47-528	996528	O-ring, outside insulator body and torch	5
	C10-W85	86W85	O-ring, insulator body center	1
	C10-106	2064106	O-ring, insulator body rear edge, red	5
	C47-998	N/A	O-ring kit, insulator body	1
	C47-006	181W89	O-ring, nozzle	1
	L47-110	37110	Electrode holder removal tool	1
	L47-075	37075	P.A. collet and wire assembly	1
	027055	N/A	Lubricant .25 oz. (7 ml) tube	1

*PolyTetraFluoroEthylene is a fluorocarbon-based polymer and is commonly abbreviated PTFE. The Teflon® brand of PTFE is manufactured only by DuPont and is not sold by Hypertherm. Hypertherm purchases other brands of PTFE from various high quality manufacturers.

C96-6100 Torch kit, PT-600/PT-19XLS quick-change includes:

Centricut part number	Reference number	Description	Pkg qty
C96-6000	0558001825	Torch base, quick-change, PT-600	1
C122-8050	0558001825	Torch head, quick-change	1
C96-042	N/A	Electrode holder mounting nut	1
C96-621	0558001621	Electrode holder	1
C122-082	N/A	Nozzle retaining cap	1
C47-944	21944	Diffuser, 100-600 amp	1
C122-072	N/A	O-ring kit, bullet plugs	1
C122-073	N/A	O-ring kit, mounting nut	1
C122-087	N/A	O-ring kit, retaining cap	1
027055	N/A	Lubricant .25 oz. (7 ml) tube	1
808900	N/A	Field service bulletin	1

C122-850 Air curtain kit, quick-change torch includes:

Centricut part number	Reference number	Description	Pkg qty
C122-391	N/A	Air curtain body, std/XC	1
C122-395	0558009395	Shield retainer, insulated, std	1
C122-394	N/A	Sleeve cap, std	1
C122-106	N/A	Coupler, air curtain	1

Centricut is not affiliated with the named manufacturers. Reference to machines, parts, descriptions, and model numbers are for convenience in verifying compatibility only. All parts are made by or for Centricut and are not made by the referenced manufacturers (unless expressly indicated). Centricut is a registered trademark of Hypertherm Inc. All other trademarks are the properties of their respective owners.

Consumables

	Centricut part number	Reference number	Description	Pkg qty
1	C47-081	37081	Shield retainer, copper	1
	C122-395	0558009395	Shield retainer, insulated, std	1
2	L47-795	21795	Shield, 50 amp	5
3	C47-802	21802	Shield, 100-250 amp	1
	C47-945	21945	Shield, 325-600 amp	1
	C122-141	0558004678	Shield, 4.1 mm, 200 amp, EPP Process	1
4	L47-796	21796	Diffuser, 50 amp	1
5	C47-944	21944	Diffuser, 100-600 amp	1
	C47-496	22496	Diffuser, 100-600 amp, reverse	1
6	C122-082	N/A	Nozzle retaining cap, quick-change	1
7	C47-082	37082	Nozzle retaining cap	1
8	C47-026	22026	Nozzle tip, .041, 50 amp	1
9	C47-029	22029	Nozzle tip, .071, 100 amp	1
	C47-030	22030	Nozzle tip, .082, 150 amp	1
	C47-031	22031	Nozzle tip, .091, 200 amp	1
	C47-922	22032	Nozzle tip, 250 amp	1
	C47-985	22034	Nozzle tip, 360 amp	1
	C47-995	22033	Nozzle tip, 400 amp	1
10	C47-027	22027	Nozzle base, 50 amp	1
11	C47-028	22028	Nozzle base, 100-400 amp	1
	C122-020	0558001883	Nozzle, 2.0 mm, 200 amp	1
12	C47-822	0558001623	Nozzle, .099, 250 amp	1
	C47-885	0558001885	Nozzle, .120, 360 amp	1
	C47-195	0558001886	Nozzle, .130, 400 amp	1
13	C96-1024*	0558001624	SilverLine® electrode, 250 amp	1
14	C96-1016*	0558002516	SilverLine electrode, 360/400 amp	1
	L96-2499	0558002499	Electrode, N ₂	5

*Centricut part features a unique Hypertherm design that differs from the OEM design.

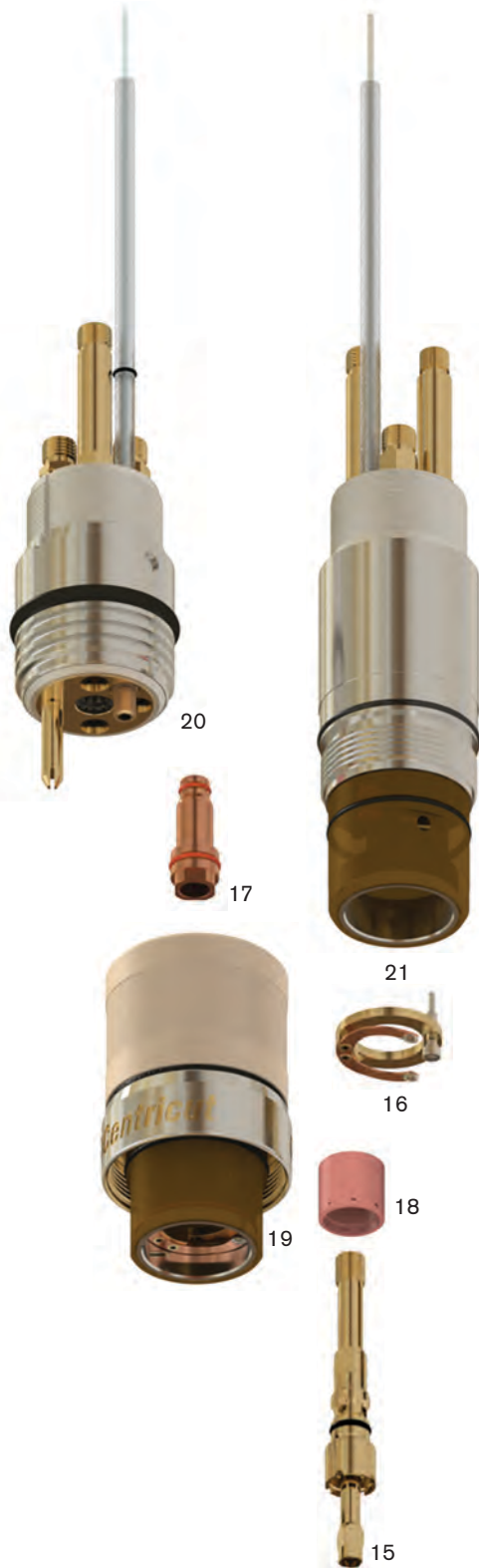

**Hypertherm technology –
SilverLine electrodes**

Maintenance items

	Centricut part number	Reference number	Description	Pkg qty
	C10-483	19483	Double threaded mounting tube	1
15	C96-621	0558001621	Electrode holder	1
16	C47-071	37071	Contact ring assembly	1
	C47-073	37073	Screw, contact ring	1
17	C96-042	N/A	Electrode holder mounting nut, PT-600	1
18	C47-142	0558002533	Gas baffle, 4 x .032, 50-200 amp	1
	L47-143	0558002534	Gas baffle, 4 x .032, 50-200 amp, reverse	1
	C122-530R	0558002530R, 35661	Gas baffle, 8 x .047, 250-600 amp, reverse	1
	C10-660	0558001625	Gas baffle, 8 X .047, 300-600 amp	1
	L47-194	22194	Gas baffle, 32 X .023, 400 amp	1
	C47-528	996528	O-ring, outside insulator body and torch	5
	C47-998	N/A	O-ring, kit, insulator body	1
	C47-083	37083	Insulator body use with C47-066	1
19	C122-8050	0558001825	Torch head, quick-change	1
20	C96-6000	0558001825	Torch base, quick-change, PT-600	1
	C96-6100	0558001825	Torch kit, quick-change, PT-600	1
21	C96-925	0558001825	Torch body assembly, modular, with insulator	1
	C122-081	N/A	I H S wire assembly kit	1
	C122-088	N/A	Bullet plug kit, quick-change torch	1
	C122-850	N/A	Air curtain kit, QC torch, std	1
	C122-391	N/A	Air curtain body, std/XC	1
	C122-106	N/A	Coupler, air curtain	1
	C122-107	N/A	O-ring kit, air curtain	1
	C47-900	N/A	Insulating tube kit, PT-19XLS/PT-600	1
	C122-072	N/A	O-ring kit, bullet plugs	1
	C122-073	N/A	O-ring kit, mounting nut	1
	C122-087	N/A	O-ring kit, retaining cap	1
	027055	N/A	Lubricant .25 oz. (7 ml) tube	1

C96-6100 Torch kit, PT-600/PT-19XLS quick-change includes:

Centricut part number	Reference number	Description	Pkg qty
C96-6000	0558001825	Torch base, quick-change, PT-600	1
C122-8050	0558001825	Torch head, quick-change	1
C96-042	N/A	Electrode holder mounting nut	1
C96-621	0558001621	Electrode holder	1
C122-082	N/A	Nozzle retaining cap	1
C47-944	21944	Diffuser, 100-600 amp	1
C122-072	N/A	O-ring kit, bullet plugs	1
C122-073	N/A	O-ring kit, mounting nut	1
C122-087	N/A	O-ring kit, retaining cap	1
027055	N/A	Lubricant .25 oz. (7 ml) tube	1
808900	N/A	Field service bulletin	1

C122-850 Air curtain kit, quick-change torch includes:

Centricut part number	Reference number	Description	Pkg qty
C122-391	N/A	Air curtain body, std/XC	1
C122-395	0558009395	Shield retainer, insulated, std	1
C122-394	N/A	Sleeve cap, std	1
C122-106	N/A	Coupler, air curtain	1

 **Centricut**[®]



Enhanced performance for ESAB PT-600® and PT-19XLS®

Centricut heavy duty consumables for ESAB torches deliver superior consumable life for all cutting processes and provide excellent cut quality and cut speed.

- Up to 30% longer consumable life compared to ESAB UL electrode
- Cutting speed and cut quality equal to ESAB
- Full product line covers all cutting amperages and processes – including 200A EPP
- High-quality parts – set to set consistency

Consumable life as measured in customer applications

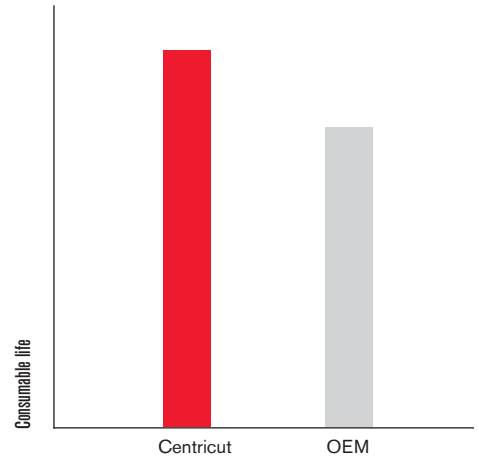

High performing consumables for ESAB PT-600 and PT-19XLS torches.

Centricut is not affiliated with the named manufacturers. Reference to machines, parts, descriptions, and model numbers are for convenience in verifying compatibility only. All parts are made by or for Centricut and are not made by the referenced manufacturers (unless expressly indicated). Centricut is a registered trademark of Hypertherm Inc. All other trademarks are the properties of their respective owners.

Consumables



Centricut part number	Reference numbers	Description	Pkg qty			
1	C47-081 C122-395	37081 0558009395	N/A N/A	Shield retainer, copper Shield retainer, insulated, std	1 1	
2	C122-130	21795	0558006130 0004470027	Shield, 3.0 mm, 35-50 amp	1	
3	C122-141 C122-166 C122-199 L47-796	0558006141 21802 21945 21796	0558004678 0558006166 0558006199 N/A	N/A Shield, 4.1 mm, 200 amp (PT-600 EPP Process) Shield, 6.6 mm, 100-250 amp Shield, 9.9 mm, 325-600 amp Diffuser, 50 amp	1 1 1 1	
4	C47-944 C47-496	21944 22496	N/A N/A	0004470031 0004470030 0004470031	Diffuser, 100-600 amp Diffuser, 100-600 amp, reverse	1 1
5	C122-082	N/A	N/A	N/A	Nozzle retaining cap, quick-change	1
6	C47-082	37082	N/A	0004470045	Nozzle retaining cap	1
7	C122-6010 C122-018 C122-020	N/A N/A N/A	0558001881 0558001882 0558001883	N/A N/A N/A	CoolFlow™ nozzle, 1.0 mm, 50 amp CoolFlow nozzle, 1.8 mm, 100 amp CoolFlow nozzle, 2.0 mm, 150-200 amp	1 1 1
	C122-023 C122-025 C122-030 C122-036 C122-041	N/A 21822 35885 22195 22401	0558001884 0558001623 0558001885 0558001886 0558001887	N/A N/A N/A N/A N/A	CoolFlow nozzle, 2.3 mm, 200 amp CoolFlow nozzle, 2.5 mm, 250 amp CoolFlow nozzle, 3.0 mm, 360 amp CoolFlow nozzle, 3.6 mm, 400 amp CoolFlow nozzle, 4.1 mm, 600 amp	1 1 1 1 1
8	C47-1096*	34086	0558004458	0004485684	SilverLine® electrode, 50-250 amp, PT-19XLS	1
9	C47-1086*	35886	0558004460	0004485829	SilverLine electrode, 360 amp, PT-19XLS	1
10	C96-1024*	0558004461	0558001624	N/A	SilverLine electrode, 250 amp, PT-600	1
11	C96-1016*	0558004462	0558002516	N/A	SilverLine electrode, 360/400 amp, PT-600	1

*Centricut part features a unique Hypertherm design that differs from the OEM design.

**Hypertherm technology –
SilverLine electrodes
and CoolFlow nozzles**

Maintenance items

	Centricut part number	Reference numbers			Description	Pkg qty
12	C47-068	37068	N/A	0004470037	Electrode holder, PT-19XLS	1
13	C96-621	N/A	0558001621	N/A	Electrode holder, PT-600	1
14	C47-071	37071	0558003858	N/A	Contact ring assembly	1
15	C47-142	948142	0558002533	0004485612	Gas baffle, 4 x .032, 50-200 amp	1
	L47-143	948143	0558002534	0004485613	Gas baffle, 4 x .032, 50-200 amp, reverse	1
	C10-660	35660	0558001625	0004485827	Gas baffle, 8 x .047, 250-600 amp	1
	C122-530R	35661	0558002530R	N/A	Gas baffle, 8 x .047, 250-600 amp, reverse	1
	L47-194	22194	0558002532	0004470097	Gas baffle, 32 x .023, 400 amp	1
16	C96-042	N/A	N/A	N/A	Electrode holder mounting nut	1
17	C122-8050	N/A	0558001825		Torch head, quick-change	1
18	C96-6000	N/A	0558001825		Torch base, quick-change, PT-600	1
	C96-6100	N/A	0558001825		Torch kit, quick-change, PT-600	1
	C47-066	37066	N/A	0004470040	Torch body, PT-19XLS	1
	C96-925	N/A	0558001825	N/A	Torch body, PT-600	1
19	C122-081	N/A	N/A	N/A	I H S wire assembly kit	1
	C122-088	N/A	N/A	N/A	Bullet plug kit, quick-change torch	1
	C122-850	N/A	N/A	N/A	Air curtain kit, quick-change torch, std	1
	C122-391	N/A	N/A	N/A	Air curtain body, std/XC	1
	C122-106	N/A	N/A	N/A	Coupler, air curtain	1
	C122-107	N/A	N/A	N/A	O-ring kit, air curtain	1
	C122-072	N/A	N/A	N/A	O-ring kit, bullet plugs	1
	C122-073	N/A	N/A	N/A	O-ring kit, mounting nut	1
	C122-087	N/A	N/A	N/A	O-ring kit, retaining cap	1
	027055	N/A	N/A	N/A	Lubricant .25 oz. (7 ml) tube	1

C96-6100 Torch kit, PT-600/PT-19XLS quick-change includes:

Centricut part number	Reference number	Description	Pkg qty
C96-6000	0558001825	Torch base, quick-change, PT-600	1
C122-8050	0558001825	Torch head, quick-change	1
C96-042	N/A	Electrode holder mounting nut	1
C96-621	0558001621	Electrode holder	1
C122-082	N/A	Nozzle retaining cap	1
C47-944	21944	Diffuser, 100-600 amp	1
C122-072	N/A	O-ring kit, bullet plugs	1
C122-073	N/A	O-ring kit, mounting nut	1
C122-087	N/A	O-ring kit, retaining cap	1
027055	N/A	Lubricant .25 oz. (7 ml) tube	1
808900	N/A	Field service bulletin	1

C122-850 Air curtain kit, quick-change torch includes:

Centricut part number	Reference number	Description	Pkg qty
C122-391	N/A	Air curtain body, std/XC	1
C122-395	0558009395	Shield retainer, insulated, std	1
C122-394	N/A	Sleeve cap, std	1
C122-106	N/A	Coupler, air curtain	1

 **Centricut**[®]



The Centricut[®] quick-change torch delivers increased performance, productivity and reliability to your ESAB[®] cutting process.

Upgrade today to a better cutting experience with the Centricut quick-change torch

- Superior replacement for ESAB PT-36, PT-600 and PT-19XLS one-piece torches
- Multiple pre-loaded torch heads allow operators to be ready for their next cutting job
- Competitively priced as compared to OEM
- Rated for applications up to 450 amps

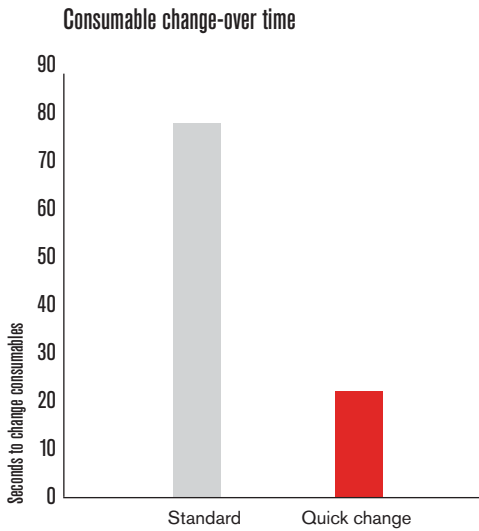

Centricut torch features:

Hypertherm engineering

Designed with proven materials and components by Hypertherm for optimal torch performance.

Two-piece design

Detachable torch head makes consumable maintenance and replacement quick and easy.

Flexibility

With just a change of the mounting nut, one torch head can be used with PT-36, PT-600 or PT-19XLS consumables.

Compatibility

Use a Centricut quick-change retaining cap to maintain standard overall torch length (important for bevel cutting). Compatible with all other Centricut or OEM consumables.

Easy installation

Check out our installation video (see below). Our torch is easy to install and fully compatible with OEM cut settings.

www.hypertherm.com/Etorchinstall



Centricut consumables further optimize your cutting process.

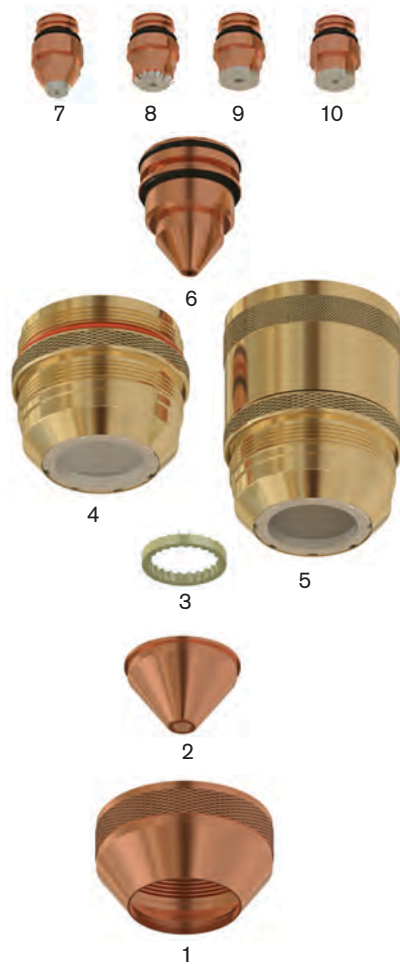

Centricut is not affiliated with the named manufacturers. Reference to machines, parts, descriptions, and model numbers are for convenience in verifying compatibility only. All parts are made by or for Centricut and are not made by the referenced manufacturers (unless expressly indicated). Centricut is a registered trademark of Hypertherm Inc. All other trademarks are the properties of their respective owners.

Consumables

Hypertherm technology -
**SilverLine electrodes
and CoolFlow nozzles**

	Centricut part number	Reference number	Description	Pkg qty
1	C47-081	37081	Shield retainer, copper	1
	C122-395	0558009395	Shield retainer, insulated, std	1
	C122-392	0558009392	Shield retainer, insulated, XC	1
2	C122-624	0558007624	Shield, 2.4 mm, 45-55 amp	1
	C122-130	0558006130	Shield, 3.0 mm, 35-50 amp	1
	C122-141	0558006141	Shield, 4.1 mm, 100-280 amp	1
	C122-166	0558006166	Shield, 6.6 mm, 260-450 amp	1
	C122-199	0558006199	Shield, 9.9 mm, 360-600 amp	1
	L47-796	21796	Diffuser, 50 amp	1
3	C47-944	21944	Diffuser, 100-600 amp	1
	C47-496	22496	Diffuser, 100-600 amp, reverse	1
4	C122-082	N/A	Nozzle retaining cap, quick-change	1
	C47-082	37082	Nozzle retaining cap	1
6	C122-908*	0558006908	CoolFlow™ nozzle, .08 mm, 35 amp	1
	C122-8010*	0558008010	CoolFlow nozzle, 1.0 mm, PR, 45-55 amp	1
	C122-6010*	0558006010	CoolFlow nozzle, 1.0 mm, 50 amp	1
	C122-014*	0558006014	CoolFlow nozzle, 1.4 mm, 100 amp	1
	C122-018*	0558006018	CoolFlow nozzle, 1.8 mm, 130 amp	1
	C122-020*	0558006020	CoolFlow nozzle, 2.0 mm, 200 amp	1
	C122-023*	0558006023	CoolFlow nozzle, 2.3 mm, 280 amp	1
	C122-025*	0558006025	CoolFlow nozzle, 2.5 mm, 300 amp	1
	C122-030*	0558006030	CoolFlow nozzle, 3.0 mm, 360 amp	1
	C122-036*	0558006036	CoolFlow nozzle, 3.6 mm, 450 amp	1
	C122-041*	0558006041	CoolFlow nozzle, 4.1 mm, 600 amp	1
7	C122-1059*	0558005459	SilverLine® electrode, O2, 45-90 amp	1
8	C122-1014*, **	0558003914	SilverLine electrode, long life, 200-450 amp	1
9	C122-1091*	0558007791, 0558003914	SilverLine electrode, O2, 260-450 amp	1
10	C122-1000*	0558012000, 0558003914	SilverLine electrode, O2, 100-450 amp, XC	1
	C122-928	0558003928	Electrode, SS/AL, 600 amp	1
	C122-548	0558009548	Shield retainer, XC	1
	C122-766	0558010766	Shield, 6.6 mm, XC	1
	C122-551	0558009551	Shield, 5.1 mm, XC	1
	C122-550	0558009550	Nozzle retaining cap, XC	1
	C122-948	N/A	Nozzle retaining cap, quick-change, XC	1
	C122-619*	0558011619	CoolFlow nozzle, 1.9 mm, 200 amp, XC	1
	C122-722*	0558010722	CoolFlow nozzle, 2.2 mm, 260 amp, XC	1
	C122-625*	0558011625	CoolFlow nozzle, 2.5 mm, 360 amp, XC	1
	C122-028*	0558006028	CoolFlow nozzle, 2.8 mm, 450 amp, XC	1

*Centricut part features a unique Hypertherm design that differs from the OEM design.

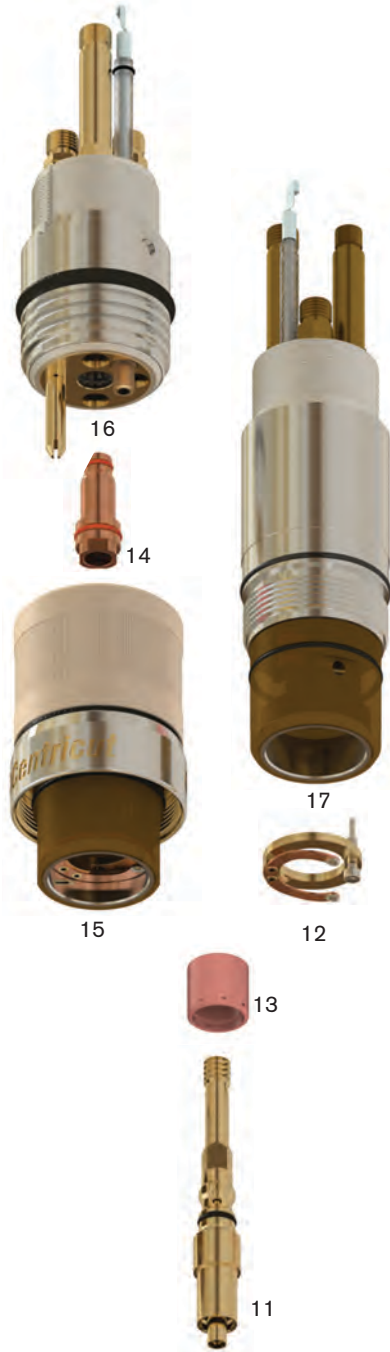
**C122-1014 electrode is not recommended for cutting below 200 amps or marking applications.

Maintenance items

	Centricut part number	Reference number	Description	Pkg qty
11	C122-924	0558003924	Electrode holder	1
12	C47-071	0558003858	Contact ring assembly	1
	C47-073	37073	Screw, contact ring	1
13	C122-457	0558005457	Gas baffle, 4X.022, 35-70 amp	1
	C122-533	0558002533	Gas baffle, 4X.032, 100-280 amp	1
	C122-530R	0558002530R, 35661	Gas baffle, 8 x .047, 250-600 amp, reverse	1
	C10-660	0558001625	Gas baffle, 8X.047, 300-600 amp	1
	L122-3918	0558003918	Electrode holder removal tool	1
	C10-483	0558001626	Double threaded mounting tube	1
14	C122-055	N/A	Electrode holder mounting nut	1
15	C122-8050	0558003804	Torch head, quick-change, PT-36	1
16	C122-8000	0558003804	Torch base, quick-change, PT-36	1
	C122-8100	0558003804	Torch kit, quick-change, PT-36	1
	C122-9100	0558003804	Torch kit, quick-change, PT-36, XC	1
17	C122-804	0558003804	Torch body	1
	C122-081	N/A	I H S wire assembly kit	1
	C122-088	N/A	Bullet plug kit, quick-change torch	1
	C122-850	N/A	Air curtain kit, quick-change torch, std	1
	C122-950	N/A	Air curtain kit, quick-change torch, XC	1
	C122-391	N/A	Air curtain body, std/XC	1
	C122-106	N/A	Coupler, air curtain	1
	C122-107	N/A	O-ring kit, air curtain	1
	C122-072	N/A	O-ring kit, bullet plugs	1
	C122-073	N/A	O-ring kit, mounting nut	1
	C122-087	N/A	O-ring kit, retaining cap	1
	027055	N/A	Lubricant .25 oz. (7 ml) tube	1

C122-8100 Torch kit, PT-36 quick-change includes:

	Centricut part number	Reference number	Description	Pkg qty
	C122-8000	N/A	Torch base, quick-change, PT-36	1
	C122-8050	N/A	Torch head, quick-change, PT-36	1
	C122-055	N/A	Electrode holder mounting nut	1
	C122-924	0558003924	Electrode holder	1
	C122-082	N/A	Nozzle retaining cap	1
	C47-944	21944	Diffuser, 100-600 amp	1
	C122-072	N/A	O-ring kit, bullet plugs	1
	C122-073	N/A	O-ring kit, mounting nut	1
	C122-087	N/A	O-ring kit, retaining cap	1
	027055	N/A	Lubricant .25 oz. (7 ml) tube	1
	808900	N/A	Field service bulletin	1

C122-9100 Torch kit, PT-36, XC quick-change includes:

	Centricut part number	Reference number	Description	Pkg qty
	C122-8000	N/A	Torch base, quick-change, PT-36	1
	C122-8050	N/A	Torch head, quick-change, PT-36	1
	C122-055	N/A	Electrode holder mounting nut	1
	C122-924	0558003924	Electrode holder	1
	C122-948	N/A	Nozzle retaining cap, quick-change, XC	1
	C47-944	21944	Diffuser, 100-600 amp	1
	C122-072	N/A	O-ring kit, bullet plugs	1
	C122-073	N/A	O-ring kit, mounting nut	1
	C122-087	N/A	O-ring kit, retaining cap	1
	027055	N/A	Lubricant .25 oz. (7 ml) tube	1
	808900	N/A	Field service bulletin	1

Centricut is not affiliated with the named manufacturers. Reference to machines, parts, descriptions, and model numbers are for convenience in verifying compatibility only. All parts are made by or for Centricut and are not made by the referenced manufacturers (unless expressly indicated). Centricut is a registered trademark of Hypertherm Inc. All other trademarks are the properties of their respective owners.

Replacement parts suitable for:
ESAB® PT-36® (m³® system)

System: ESP®-200/300/400/600C/1000, EPP-200, 360

C122-850 Air curtain kit, quick-change torch includes:

Centricut part number	Reference number	Description	Pkg qty
C122-391	N/A	Air curtain body, std/XC	1
C122-395	0558009395	Shield retainer, insulated, std	1
C122-394	N/A	Sleeve cap, std	1
C122-106	N/A	Coupler, air curtain	1

C122-950 Air curtain kit, quick-change torch, XC includes:

Centricut part number	Reference number	Description	Pkg qty
C122-391	N/A	Air curtain body, std/XC	1
C122-392	0558009392	Shield retainer, insulated, XC	1
C122-393	N/A	Sleeve cap, XC	1
C122-106	N/A	Coupler, air curtain	1



Centricut is not affiliated with the named manufacturers. Reference to machines, parts, descriptions, and model numbers are for convenience in verifying compatibility only. All parts are made by or for Centricut and are not made by the referenced manufacturers (unless expressly indicated). Centricut is a registered trademark of Hypertherm Inc. All other trademarks are the properties of their respective owners.

Centricut® ESAB® Air Curtain

System: ESP®-200/300/400/600C/1000, EPP-200, 360, PCM®-150/1500

For quick-change torches: PT-36, PT-600 and PT-19XLS

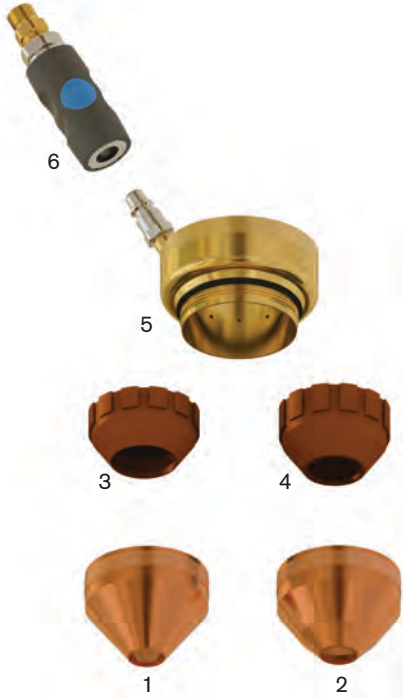

Centricut part number	Reference number	Description	Pkg qty	
1	C122-394	N/A	Sleeve cap, std	1
2	C122-393	N/A	Sleeve cap, XC	1
3	C122-395	0558009395	Shield retainer, insulated, std	1
4	C122-392	0558009392	Shield retainer, insulated, XC	1
5	C122-391	N/A	Air curtain body, std/XC	1
6	C122-106	N/A	Coupler, air curtain	1
	C122-850	N/A	Air curtain kit, quick-change torch, std	1
	C122-950	N/A	Air curtain kit, quick-change torch, XC	1
	C122-107	N/A	O-ring kit, air curtain	1

C122-850 Air curtain kit, quick-change torch includes:

Centricut part number	Reference number	Description	Pkg qty
C122-391	N/A	Air curtain body, std/XC	1
C122-395	0558009395	Shield retainer, insulated, std	1
C122-394	N/A	Sleeve cap, std	1
C122-106	N/A	Coupler, air curtain	1

C122-950 Air curtain kit, quick-change torch, XC includes:

Centricut part number	Reference number	Description	Pkg qty
C122-391	N/A	Air curtain body, std/XC	1
C122-392	0558009392	Shield retainer, insulated, XC	1
C122-393	N/A	Sleeve cap, XC	1
C122-106	N/A	Coupler, air curtain	1



Replacement parts suitable for: Kaliburn® FineLine™ 200

System: FineLine™ 200PC and 150PC

Consumables

	Centricut part number	Reference number	Description	Pkg qty
1	C104-210	BK200210	Outer cap	1
2	I104-230	BK200230	Shield cap, 30 amp, MS/AL	1
	I104-233	BK200233	Shield cap, 30 amp, SS	1
	I104-237	BK200237	Shield cap, 50 amp, SS	1
	C104-231	BK200231	Shield cap, 50-70 amp, MS/SS/AL	1
	C104-232	BK200232	Shield cap, 100 amp, MS/SS/AL	1
3	C104-234	BK200234	Shield cap, 200 amp, MS/SS/AL	1
	C104-217	BK200217	Retaining cap, 30/50/70 amp, MS	1
	C104-218	BK200218	Retaining cap, 100 amp, MS	1
	C107-266	BK277266, BK200219	Retaining cap, 200/275 amp, MS/SS/AL	1
	I104-222	BK200222	Nozzle, 30 amp, MS/AL	1
4	I104-228	BK200228	Nozzle, 30 amp, SS	1
	I104-229	BK200229	Nozzle, 50 amp, SS	1
	C104-223	BK200223	Nozzle, 50 amp, MS/AL	1
	C104-224	BK200224	Nozzle, 70 amp, MS	1
	I104-240	BK200240	Nozzle, 70 amp, AL/SS	1
5	C104-225	BK200225	Nozzle, 100 amp, MS	1
	C104-239	BK200239	Nozzle, 100 amp, AL/SS	1
	C104-227	BK200227	Nozzle, 200 amp, MS/SS/AL	1
6	I104-279	BK200279	Swirl ring, 30 amp, SS	1
	C104-277	BK200277	Swirl ring, 100 amp, MS	1
7	C104-221	BK200221	Swirl ring, 200 amp, MS	1
	I104-213	BK200213	Electrode, 30 amp, MS/AL	1
	I104-238	BK200238	Electrode, 30-50 amp, SS	1
8	C104-214	BK200214	Electrode, 50-70 amp, MS	1
	C104-1005	BK200215	SilverLine® electrode, 100 amp, MS	1
	C104-215	BK200215	Electrode, 100 amp, MS	1
	C104-115	BK202115	Electrode, 200 amp, MS	1
9	C104-1015	BK202115	SilverLine electrode, 200 amp, MS	1

Maintenance items

	Centricut part number	Reference number	Description	Pkg qty
10	C104-112	BK200112	Cooling tube	1
	C104-109	BK200109	Wrench, cooling tube	1
11	I104-200	BK200000	Torch body	1
	027055	N/A	Lubricant .25 oz. (7 ml) tube	1



**Hypertherm technology –
SilverLine electrodes**

System: SR-45i®

Consumables

	Centricut part number	Reference number	Description	Pkg qty
1	I36-098	BK770098	Retaining cap	1
2	C36-030	BK770030	Nozzle, insulation	5
3	C36-104	BK770104	Nozzle, tapered	5
4	C36-000	BK770000	Nozzle, Air	5
5	C36-012	BK770012	Swirl ring	1
6	C36-715*	BK770015/BK770017	Electrode, Air	5

Maintenance items

	Centricut part number	Reference number	Description	Pkg qty
7	I36-073	BK770073	Torch body	1
	136-072	BK770072	O-ring	5
	027055	N/A	Lubricant .25 oz. (7 ml) tube	1

*Centricut part features a unique Hypertherm design that differs from the OEM design.

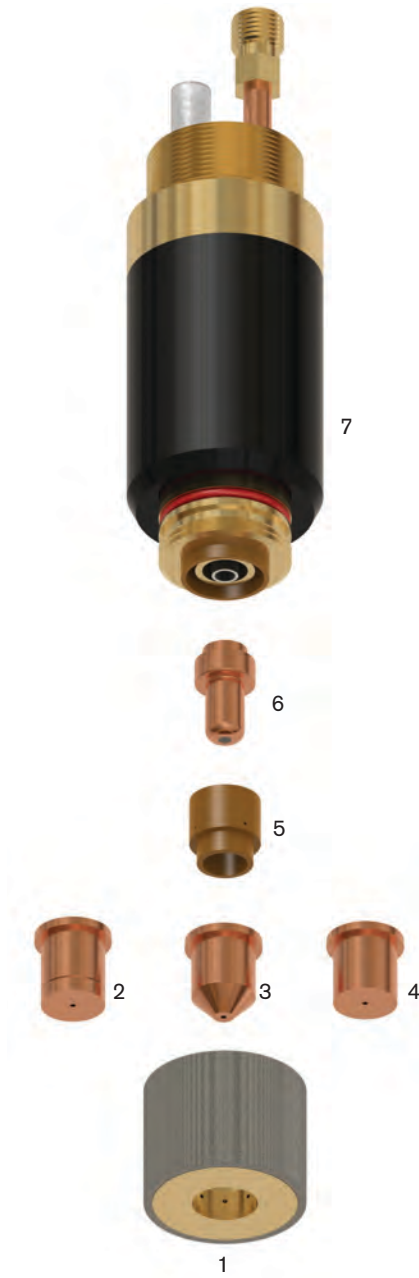

System: SR-45i®

Consumables

	Centricut part number	Reference number	Description	Pkg qty
1	020104	020104	Retaining cap	1
2	C02-102	020102	Nozzle	10
3	C02-131	020131	Nozzle, pipe	10
4	C02-115	020115	Nozzle	10
5	020466	020466	Nozzle, extended	5
6	C02-101	020101	Swirl ring	1
7	C02-103	020103	Electrode, Air	10
8	020467	020467	Electrode, Air, extended	5

Maintenance items

	Centricut part number	Reference number	Description	Pkg qty
	C02-016	044016	O-ring	5
9	C36-973	N/A	Retrofit modular torch body	1
	027055	N/A	Lubricant .25 oz. (7 ml) tube	1

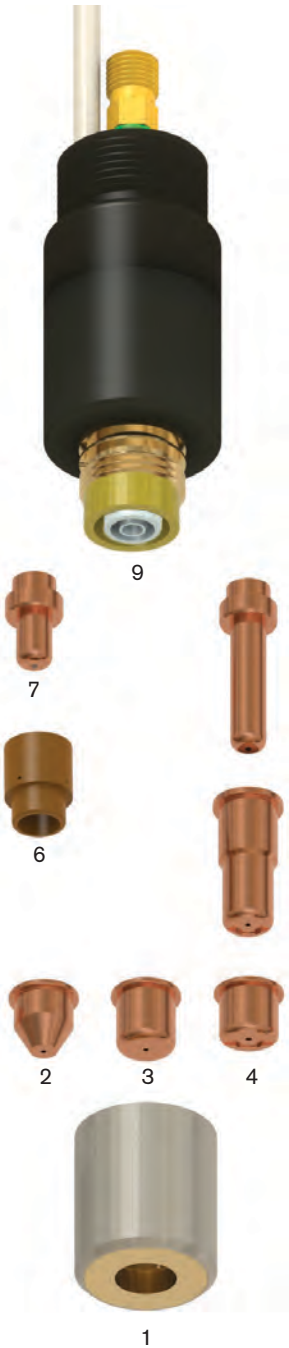

Superior performance for Kaliburn® Spirit I®, Spirit II®, and ProLine® systems

Centricut torches and consumables lower your cost of cutting, improve cut quality, increase productivity and ensure process reliability.

- Two to three times longer consumable life with improved cut quality up to 275 A
- 50% longer consumable life cutting at 400 A
- Improved swirl ring design is more robust than Kaliburn
- High-quality parts – set to set consistency
- Centricut quick change torch gives fast job changeover and easy consumables change
- Superior performance at a lower price for your Kaliburn Spirit and ProLine systems

Check out our torch installation video. The Centricut quick change torch is easy to install and fully compatible with OEM cut settings.

www.hypertherm.com/ktorchinstall

Consumable life with ISO 9013.2002 (E) cut quality ranges noted

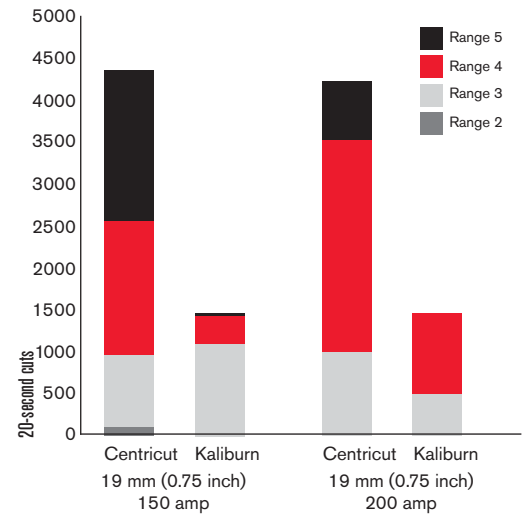

Centricut is not affiliated with the named manufacturers. Reference to machines, parts, descriptions, and model numbers are for convenience in verifying compatibility only. All parts are made by or for Centricut and are not made by the referenced manufacturers (unless expressly indicated). Centricut is a registered trademark of Hypertherm Inc. All other trademarks are the properties of their respective owners.

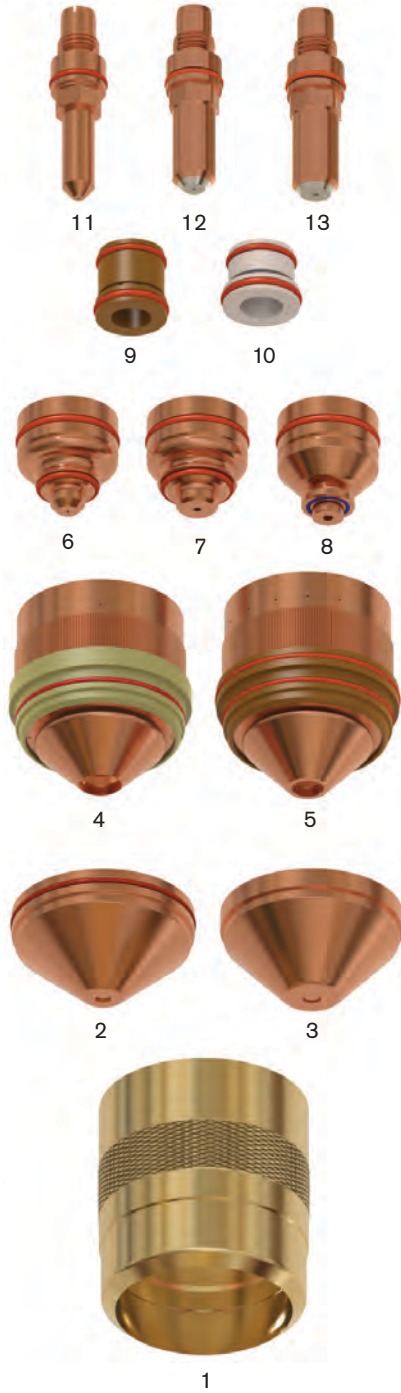
Consumables

**Hypertherm technology –
SilverLine electrodes
and CoolFlow nozzles**

	Centricut part number	Reference number	Description	Pkg qty	
1	C107-154	BK277154	Outer cap, 30-275 amp	1	
	C107-050	BK284150	Outer cap, 400 amp	1	
2	C107-145	BK277145	Shield cap, 30 amp, MS/AL	1	
	C107-144	BK277144	Shield cap, 30 amp, SS, Air	1	
	C107-115	BK277115	Shield cap, 50 amp, MS	1	
	C107-149	BK277149	Shield cap, 50 amp, SS, Air	1	
	C107-150	BK277150	Shield cap, 70 amp, MS/SS/AL	1	
	C107-286	BK277286	Shield cap, 100 amp, MS/SS/AL, Air	1	
	I107-146	BK277146	Shield Ring, 100 amp, SS, H17	1	
	C107-117	BK277117	Shield cap, 150 amp, MS/SS/AL	1	
	C107-274	BK277274	Shield cap, 200 amp, MS/SS/AL	1	
	C107-263	BK277263	Shield cap, 275 amp, MS/SS/AL	1	
3	C107-123	BK284123	Shield cap, 400 amp, MS	1	
4	C107-153	BK277153	Retaining cap, 30/50/070 amp, MS/SS/AL	1	
	C107-110	BK277110	Retaining cap, 30/150 amp SS, Air	1	
	C107-151	BK277151	Retaining cap, 100/150 amp, MS/SS/AL	1	
	C107-152	BK277152	Retaining cap, 150 amp, MS/SS/AL	1	
	I107-113	BK277113	Retaining cap, 200 amp SS, H17	1	
	C107-266	BK277266	Retaining cap, 200/275 amp, MS/SS/AL	1	
	5	C107-121	BK284121	Retaining cap, 400 amp, MS	1
	6	C107-120*	BK277120	CoolFlow™ nozzle, 30 amp, MS/AL	1
		C107-021*	BK277121	CoolFlow nozzle, 30 amp, SS, Air	1
		C107-122*	BK277122	CoolFlow nozzle, 50 amp, MS/AL	1
C107-023*		BK277123	CoolFlow nozzle, 50 amp, SS, Air	1	
C107-125*		BK277125	CoolFlow nozzle, 70 amp, MS/SS/AL	1	
I107-124		BK277124	Nozzle, 70 amp, SS, H17	1	
C107-284*		BK277284	CoolFlow nozzle, 100 amp, MS/SS/AL, Air	1	
I107-126		BK277126	Nozzle, 100 amp, SS, H17	1	
7		C107-293*	BK277293	CoolFlow nozzle, 150 amp, MS/SS/AL, Air	1
I107-297		BK277297	Nozzle, 150 amp, SS, H17	1	
C107-289*	BK277289	CoolFlow nozzle, 200 amp, MS/SS/AL, Air	1		
C107-269*	BK277269	CoolFlow nozzle, 275 amp, MS	1		
C107-276*	BK277276	CoolFlow nozzle, 275 amp, SS/AL	1		
8	C107-025*	BK284125	CoolFlow nozzle, 400 amp, MS	1	
	9	C107-140	BK277140	Swirl ring, 30/50/70 amp, MS/SS/AL, H17	1
	C107-138	BK277138	Swirl ring, 30 amp, SS, Air	1	
	C107-142	BK277142	Swirl ring, 50/70 amp, MS/SS/AL, Air	1	
	C107-283*	BK277283	Swirl ring, 100 amp, MS/SS/AL, Air	1	
	I107-141	BK277141	Swirl Ring, 100 amp, SS, H17	1	
	10	C107-139*	BK277139	Swirl ring, 150 amp, MS/SS/AL	1
	C107-143*	BK277143	Swirl ring, 200 amp, MS/SS/AL	1	
	C107-259*	BK277259	Swirl ring, 200 amp, SS, H17	1	
	C107-258*	BK277258	Swirl ring, 275 amp, MS/SS/AL	1	
C107-022*	BK284122	Swirl ring, 400 amp, MS/SS/AL	1		
11	C107-130	BK277130	Electrode, 30 amp, MS/AL	1	
	C107-137	BK277137	Electrode, 30/50 amp, SS, Air	1	
	C107-131	BK277131	Electrode, 50/70 amp, MS/SS/AL	1	
	I107-132	BK277132	Electrode, 70 amp, SS, H17	1	
	12	C107-1082*	BK277282	SilverLine® electrode, 100 amp, MS/SS/AL	1
I107-133	BK277133	Electrode, 100 amp, SS, H17	1		
C107-1092*	BK277292	SilverLine electrode, 150 amp, MS/SS/AL	1		
I107-135	BK277135	Electrode, 150 amp, SS, H17	1		
C107-1091*	BK277291	SilverLine electrode, 200 amp, MS/SS/AL	1		
C107-1070*	BK277270	SilverLine electrode, 275 amp, MS/SS/AL	1		
13	C107-1024*	BK284124	SilverLine electrode, 400 amp, MS	1	

*Centricut part features a unique Hypertherm design that differs from the OEM design.

Centricut is not affiliated with the named manufacturers. Reference to machines, parts, descriptions, and model numbers are for convenience in verifying compatibility only. All parts are made by or for Centricut and are not made by the referenced manufacturers (unless expressly indicated). Centricut is a registered trademark of Hypertherm Inc. All other trademarks are the properties of their respective owners.

Maintenance items

	Centricut part number	Reference number	Description	Pkg qty
	C23-001	N/A	Swirl ring removal tool (up to 275 amp only)	1
	C107-007	BK277007	Cooling tube	1
	C107-091	N/A	O-ring kit, torch head	1
	C107-126	N/A	O-ring kit, rear torch plugs	1
14	C107-9150	BK279150	Torch head, Spirit 150-275	1
	C107-9100	BK279100	Torch head, Spirit 400	1
15	C107-9050	BK279050	Torch base, Spirit 150-275	1
	C107-9000	BK279000	Torch base, Spirit 400	1
	C107-1050	N/A	Torch kit, Spirit 150-275	1
	C107-1000	N/A	Torch kit, Spirit 400	1
	C107-300	N/A	Plasma gas tube	1
	I107-056	BK277056	Nozzle removal tool	1
	I107-7087	BK277087	Kaliburn electrode tool	1
	Q27055	N/A	Lubricant .25 oz. (7 ml) tube	1

C107-1050 Torch kit, Spirit 150-275 includes:

	Centricut part number	Reference number	Description	Pkg qty
	C107-9050	BK279050	Torch base, Spirit 150-275	1
	C107-9150	BK279150	Torch head, Spirit 150-275	1
	C107-300	N/A	Plasma gas tube	1
	N/A	N/A	Insulation material	1
	808040	N/A	Field service bulletin	1

C107-1000 Torch kit, Spirit 400 includes:

	Part number	Reference number	Description	Pkg qty
	C107-9000	BK279000	Torch base, Spirit 400	1
	C107-9100	BK279100	Torch head, Spirit 400	1
	C107-300	N/A	Plasma gas tube	1
	N/A	N/A	Insulation material	1
	808040	N/A	Field service bulletin	1

**Hypertherm technology –
SilverLine electrodes
and CoolFlow nozzles**

Kjellberg® HiFocus 100®

Torch: PerCut 101®

Consumables – Carbon steel

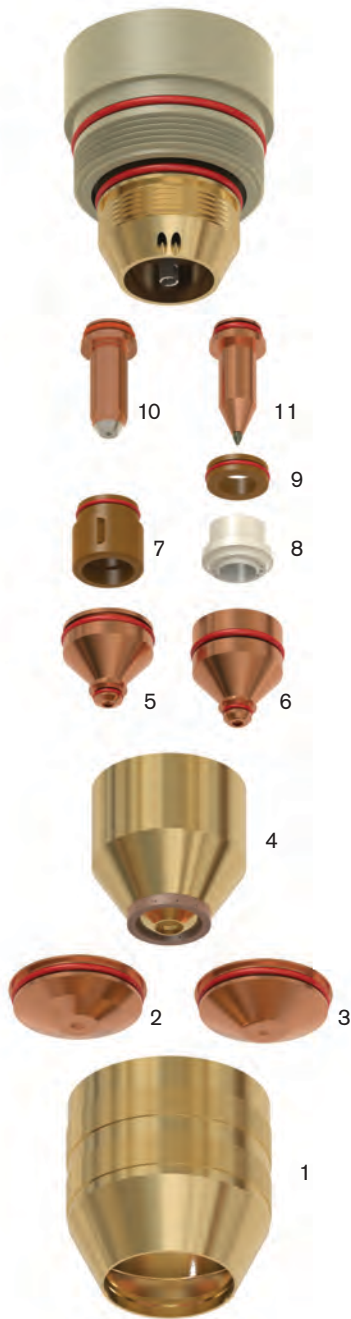

**Hypertherm technology –
SilverLine electrodes**

	Centricut part number	Reference number	Alternate reference	Description	Pkg qty
1	C106-081	.11.835.201.081	Z501	Protection cap	1
2	C106-561	.11.835.201.1561	Z4015	Swirl gas cap, 1.5 mm	1
	C106-571	.11.835.201.1571	Z4020	Swirl gas cap, 2.0 mm	1
	C106-581	.11.835.201.1581	Z4025	Swirl gas cap, 2.5 mm	1
	C106-591	.11.835.201.1591	Z4030	Swirl gas cap, 3.0 mm	1
	C106-171	.11.835.401.1571	Z4140	Swirl gas cap, 4.0 mm	1
4	C106-160	.11.835.201.160	Z3004	Nozzle cap, complete, 0.4 mm	1
	C106-162	.11.835.201.162	Z3008	Nozzle cap complete, 0.8 mm	1
5	C106-406	.11.835.221.406	Z2006	Nozzle, 0.6 mm	10
	C106-407	.11.835.221.407	Z2007	Nozzle, 0.7 mm	10
	C106-408	.11.835.221.408	Z2008	Nozzle, 0.8 mm	10
	C106-409	.11.836.221.409	Z2009	Nozzle, 0.9 mm	10
	C106-410	.11.835.221.410	Z2010	Nozzle, 1.0 mm	10
	C106-411	.11.835.221.411	Z2011	Nozzle, 1.1 mm	10
	C106-412	.11.835.421.412	Z2112	Nozzle, 1.2 mm	10
	C106-112	.11.835.221.412	Z2012	Nozzle, 1.2 mm	10
	C106-414	.11.835.421.414	Z2114	Nozzle, 1.4 mm	10
7	C106-153	.11.835.221.153	Z101	Gas guide cap, 0.4 mm	1
8	K106-253	.11.834.321.153	Z111	Gas guide cap	1
9	C106-303	.11.835.421.303	Z111A	Spacer	1
10	C106-1021*	.11.835.421.3101	Z012	SilverLine® electrode	1
	C106-1001*	.11.835.221.3101	Z002	SilverLine electrode	1

Consumables – Stainless steel and aluminum

	Centricut part number	Reference number	Alternate reference	Description	Pkg qty
1	C106-081	.11.835.201.081	Z501	Protection cap	1
3	C106-1571	.11.835.411.1571	Z4520	Swirl gas cap, 2.0 mm	1
	C106-1581	.11.835.411.1581	Z4530	Swirl gas cap, 3.0 mm	1
	C106-1591	.11.835.411.1591	Z4540	Swirl gas cap, 4.0 mm	1
4	C106-162	.11.835.201.162	Z3008	Nozzle cap complete, 0.8 mm	1
5	C106-406	.11.835.221.406	Z2006	Nozzle, 0.6 mm	10
	C106-407	.11.835.221.407	Z2007	Nozzle, 0.7 mm	10
	C106-408	.11.835.221.408	Z2008	Nozzle, 0.8 mm	10
	C106-410	.11.835.221.410	Z2010	Nozzle, 1.0 mm	10
6	C106-610	.11.835.411.610	Z2510	Nozzle, 1.0 mm	5
	C106-612	.11.835.411.612	Z2512	Nozzle, 1.2 mm	5
	C106-614	.11.835.411.614	Z2514	Nozzle, 1.4 mm	5
	C106-616	.11.835.411.616	Z2516	Nozzle, 1.6 mm	5
7	C106-153	.11.835.221.153	Z101	Gas guide cap, 0.4 mm	1
8	K106-253	.11.834.321.153	Z111	Gas guide cap	1
9	C106-303	.11.835.421.303	Z111A	Spacer	1
11	C106-101	.11.835.211.5101	Z042	Electrode	1
	C106-5101	.11.835.411.5101	Z052	Electrode	1

Maintenance items

	Centricut part number	Reference number	Description	Pkg qty
	027055	N/A	Lubricant .25 oz. (7 ml) tube	1

*Centricut part features a unique Hypertherm design that differs from the OEM design.

Consumables – Carbon steel

**Hypertherm technology –
SilverLine electrodes**

	Centricut part number	Reference number	Alternate reference	Description	Pkg qty
1	C106-081	.11.835.201.081	Z501	Protection cap	1
2	C106-561	.11.835.201.1561	Z4015	Swirl gas cap, 1.5 mm	1
	C106-571	.11.835.201.1571	Z4020	Swirl gas cap, 2.0 mm	1
	C109-551	.11.835.201.1551	Z4022	Swirl gas cap, 2.2 mm	1
	C106-581	.11.835.201.1581	Z4025	Swirl gas cap, 2.5 mm	1
	C106-591	.11.835.201.1591	Z4030	Swirl gas cap, 3.0 mm	1
	C106-171	.11.835.401.1571	Z4140	Swirl gas cap, 4.0 mm	1
4	K109-160	.11.842.401.160	S3004	Nozzle cap, 0.4 mm	1
	C109-162	.11.842.401.162	S3008	Nozzle cap, 0.8 mm	1
	C109-622	.11.842.401.1622	S3028	Nozzle cap, 0.8 mm	1
5	C109-406	.11.843.021.406	S2006Y	Nozzle, 0.6 mm, 25 amp	10
	C109-407	.11.843.021.407	S2007Y	Nozzle, 0.7 mm, 35 amp	10
	C109-408	.11.843.021.408	S2008Y	Nozzle, 0.8 mm, 50/60 amp	10
	C109-409	.11.843.021.409	S2009Y	Nozzle, 0.9 mm, 70/80 amp	10
	C109-410	.11.843.021.410	S2010Y	Nozzle, 1.0 mm, 80/90 amp	10
	C109-411	.11.843.021.411	S2011Y	Nozzle, 1.1 mm, 90/100 amp	10
	C109-112	.11.843.121.412	S2112Y	Nozzle, 1.2 mm, 100 amp	10
	C109-412	.11.843.021.412	S2012Y	Nozzle, 1.2 mm, 100/130 amp	10
	C109-414	.11.843.021.414	S2014Y	Nozzle, 1.4 mm, 130/160 amp	10
	C109-114	.11.843.121.414	S2114Y	Nozzle, 1.4 mm, 130 amp	10
	C109-416	.11.843.021.416	S2016Y	Nozzle, 1.6 mm, 160 amp	10
	C109-116	.11.843.121.416	S2116Y	Nozzle, 1.6 mm, 160 amp	10
7	C106-153	.11.835.221.153	Z101	Gas guide cap, 0.4 mm	1
	C109-154	.11.835.221.154	Z102	Gas guide cap	1
8	K106-253	.11.834.321.153	Z111	Gas guide cap	1
9	C106-303	.11.835.421.303	Z111A	Spacer	1
10	C109-1010*	.11.843.021.310	S002Y	SilverLine® electrode, XL	1
	C109-1030*	.11.843.121.310	S012Y	SilverLine electrode, XL	1

Consumables – Stainless steel and aluminum

	Centricut part number	Reference number	Alternate reference	Description	Pkg qty
1	C106-081	.11.835.201.081	Z501	Protection cap	1
3	C106-1581	.11.835.411.1581	Z4530	Swirl gas cap, 3.0 mm	1
	C109-580	.11.835.411.1580	Z4535	Swirl gas cap, 3.5 mm	1
	C106-1591	.11.835.411.1591	Z4540	Swirl gas cap, 4.0 mm	1
	C109-590	.11.835.411.1590	Z4545	Swirl gas cap, 4.5 mm	1
4	C109-162	.11.842.401.162	S3008	Nozzle cap, 0.8 mm	1
	C109-621	.11.842.401.1621	Z3018	Nozzle cap, 0.8 mm	1
6	C109-407	.11.843.021.407	S2007Y	Nozzle, 0.7 mm, 35 amp	10
	C109-408	.11.843.021.408	S2008Y	Nozzle, 0.8 mm, 50/60 amp	10
	C109-614	.11.843.111.614	S2514Y	Nozzle, 1.4 mm, 120 amp	5
	C109-616	.11.843.111.616	S2516Y	Nozzle, 1.6 mm, 140 amp	5
	C109-618	.11.843.111.618	S2518Y	Nozzle, 1.8 mm, 160 amp	5
7	C106-153	.11.835.221.153	Z101	Gas guide cap, 0.4 mm	1
8	K106-253	.11.834.321.153	Z111	Gas guide cap	1
11	C109-510	.11.842.411.510	S042	Electrode	1
	C109-1510	.11.842.511.510	S052	Electrode	1

Maintenance items

	Centricut part number	Reference number	Alternate reference	Description	Pkg qty
	K109-152	.11.842.401.152	S901	Cooling tube	5
	027055	N/A		Lubricant .25 oz. (7 ml) tube	1

*Centricut part features a unique Hypertherm design that differs from the OEM design.

Centricut is not affiliated with the named manufacturers. Reference to machines, parts, descriptions, and model numbers are for convenience in verifying compatibility only. All parts are made by or for Centricut and are not made by the referenced manufacturers (unless expressly indicated). Centricut is a registered trademark of Hypertherm Inc. All other trademarks are the properties of their respective owners.

Consumables – Carbon steel

	Centricut part number	Reference number	Alternate reference	Description	Pkg qty
1	C124-081	.11.848.201.081	G501	Protection cap, 20–200 amp	1
2	C124-515	.11.848.201.1515	G4015	Swirl gas cap, 20 amp	1
	C124-520	.11.848.201.1520	G4020	Swirl gas cap, 60 amp	1
	C124-525	.11.848.201.1525	G4025	Swirl gas cap, 90–130 amp	1
	C124-530	.11.848.201.1530	G4030	Swirl gas cap, 90–200 amp	1
	C124-535	.11.848.201.1535	G4035	Swirl gas cap, 200 amp, Contour Cut	1
	C124-540	.11.848.201.1540	G4040	Swirl gas cap, 200 amp, Contour Cut	1
	C124-604	.11.848.201.1604	G3004	Nozzle cap, 20–35 amp	1
3	C124-628	.11.848.201.1628	G3028	Nozzle cap, 60–200 amp	1
4	C124-406*	.11.848.221.406	G2006Y	CoolFlow™ Nozzle, 25 amp	5
	C124-407*	.11.848.221.407	G2007Y	CoolFlow Nozzle, 35 amp	5
	C124-408*	.11.848.221.408	G2008Y	CoolFlow nozzle, 60 amp	5
	C124-410*	.11.848.221.410	G2010Y	CoolFlow nozzle, 90 amp	5
	C124-412*	.11.848.221.412	G2012Y	CoolFlow nozzle, 130 amp	5
	C124-414*	.11.848.221.414	G2014Y	CoolFlow nozzle, 160 amp	5
	C124-417*	.11.848.221.417	G2017Y	CoolFlow nozzle, 200 amp	5
5	C124-145	.11.848.221.145	G101	Gas guide, Low amperage and Contour Cut	1
	C124-145C	.11.848.221.145C	G101C	Gas guide, 20–200 amp	1
	C124-146	.11.848.221.146	G102	Gas guide, 60–200 amp	1
6	C124-1000*	.11.848.221.300	G002Y	SilverLine® electrode, 20–200 amp	1
	C124-142	.11.848.201.142	G901Y	Cooling tube, 20–200 amp	1

*Centricut part features a unique Hypertherm design that differs from the OEM design.



**Hypertherm technology –
SilverLine electrodes and
CoolFlow™ nozzles**

Consumables – Carbon steel

**Hypertherm technology –
SilverLine electrodes and
CoolFlow™ nozzles**

	Centricut part number	Reference number	Alternate reference	Description	Pkg qty
1	C124-981	.11.852.201.081	G502	Protection cap, 20–200 amp	1
2	C124-515	.11.848.201.1515	G4015	Swirl gas cap, 20 amp	1
	C124-520	.11.848.201.1520	G4020	Swirl gas cap, 60 amp	1
	C124-525	.11.848.201.1525	G4025	Swirl gas cap, 90–130 amp	1
	C124-530	.11.848.201.1530	G4030	Swirl gas cap, 90 – 200 amp	1
	C124-535	.11.848.201.1535	G4035	Swirl gas cap, 200 amp, Contour Cut	1
	C124-540	.11.848.201.1540	G4040	Swirl gas cap, 200 amp, Contour Cut	1
3	C124-604	.11.848.201.1604	G3004	Nozzle cap, 20–35 amp	1
	C124-628	.11.848.201.1628	G3028	Nozzle cap, 60–200 amp	1
4	C124-406*	.11.848.221.406	G2006Y	CoolFlow™ nozzle, 25 amp	5
	C124-407*	.11.848.221.407	G2007Y	CoolFlow nozzle, 35 amp	5
	C124-408*	.11.848.221.408	G2008Y	CoolFlow nozzle, 60 amp	5
	C124-410*	.11.848.221.410	G2010Y	CoolFlow nozzle, 90 amp	5
	C124-412*	.11.848.221.412	G2012Y	CoolFlow nozzle, 130 amp	5
	C124-414*	.11.848.221.414	G2014Y	CoolFlow nozzle, 160 amp	5
	C124-417*	.11.848.221.417	G2017Y	CoolFlow nozzle, 200 amp	5
5	C124-145C	.11.848.221.145C	G101C	Gas guide, 20–200 amp	1
	C124-045	.11.848.421.145	G121	Gas guide, 280–400 amp	1
6	C124-1020*	.11.848.231.320	G011Y	SilverLine® electrode, 20–60 amp	1
	C124-1050*	.11.848.231.350	G015Y	SilverLine electrode, 90–160 amp	1
	C124-1060*	.11.848.231.360	G016Y	SilverLine electrode, 200 amp	1
	C124-1142	.11.852.201.142	G902Y	Cooling tube, 20–200 amp	1
	C124-142	.11.848.201.142	G901Y	Cooling tube, 20–200 amp	1

*Centricut part features a unique Hypertherm design that differs from the OEM design.



Consumables for Kjellberg® PerCut 370 torches

Centricut consumables offer long life while delivering excellent quality and productivity.

- Competitively priced compared to Kjellberg
- Stainless steel consumables for PerCut 370.1 last more than 33% longer than Kjellberg
- Speed and cut quality equal to Kjellberg
- High-quality parts – set to set consistency
- Full product line including consumables for mild steel and stainless steel cutting



Mild steel and stainless steel cutting consumables for HiFocus 280i/360i/440i.

Consumables – Carbon steel

	Centricut part number	Reference number	Alternate reference	Description	Pkg qty
1	C106-081	.11.835.201.081	Z501	Protection cap	1
2	C106-561	.11.835.201.1561	Z4015	Swirl gas cap, 1.5 mm	1
	C106-571	.11.835.201.1571	Z4020	Swirl gas cap, 2.0 mm	1
	C109-551	.11.835.201.1551	Z4022	Swirl gas cap, 2.2 mm	1
	C106-581	.11.835.201.1581	Z4025	Swirl gas cap, 2.5 mm	1
	C106-591	.11.835.201.1591	Z4030	Swirl gas cap, 3.0 mm	1
	C106-171	.11.835.401.1571	Z4140	Swirl gas cap, 4.0 mm	1
	C106-1591	.11.835.411.1591	Z4540	Swirl gas cap, 4.0 mm	1
4	K109-160	.11.842.401.160	S3004	Nozzle cap, 0.4 mm	1
	C109-622	.11.842.401.1622	S3028	Nozzle cap, 0.8 mm	1
5	C109-406	.11.843.021.406	S2006Y	Nozzle, 0.6 mm, 25 amp	10
	C109-407	.11.843.021.407	S2007Y	Nozzle, 0.7 mm, 35 amp	10
	C109-408	.11.843.021.408	S2008Y	Nozzle, 0.8 mm, 50/60 amp	10
	C109-409	.11.843.021.409	S2009Y	Nozzle, 0.9 mm, 70/80 amp	10
	C109-410	.11.843.021.410	S2010Y	Nozzle, 1.0 mm, 80/90 amp	10
	C109-411	.11.843.021.411	S2011Y	Nozzle, 1.1 mm, 90/100 amp	10
	C109-112	.11.843.121.412	S2112Y	Nozzle, 1.2 mm, 100 amp	10
	C109-412	.11.843.021.412	S2012Y	Nozzle, 1.2 mm, 100/130 amp	10
	C109-114	.11.843.121.414	S2114Y	Nozzle, 1.4 mm, 130 amp	10
	C109-414	.11.843.021.414	S2014Y	Nozzle, 1.4 mm, 130/160 amp	10
	C109-416	.11.843.021.416	S2016Y	Nozzle, 1.6 mm, 160 amp	10
	C109-116	.11.843.121.416	S2116Y	Nozzle, 1.6 mm, 160 amp	10
7	C106-153	.11.835.221.153	Z101	Gas guide cap, 0.4 mm	1
	C109-154	.11.835.221.154	Z102	Gas guide cap, 0.4 mm	1
8	K106-253	.11.834.321.153	Z111	Gas guide cap	1
9	C106-303	.11.835.421.303	Z111A	Spacer	1
10	C109-1010*	.11.843.021.310	S002Y	SilverLine® electrode, XL	1
	C109-1030*	.11.843.121.310	S012Y	SilverLine electrode, XL	1
	K109-152	.11.842.401.152	S901	Cooling tube	5

Consumables – Stainless steel and aluminum

	Centricut part number	Reference number	Alternate reference	Description	Pkg qty
1	C106-081	.11.835.201.081	Z501	Protection cap	1
2	C106-571	.11.835.201.1571	Z4020	Swirl gas cap, 2.0 mm	1
3	C106-1581	.11.835.411.1581	Z4530	Swirl gas cap, 3.0 mm	1
	C109-580	.11.835.411.1580	Z4535	Swirl gas cap, 3.5 mm	1
	C106-1591	.11.835.411.1591	Z4540	Swirl gas cap, 4.0 mm	1
	C109-590	.11.835.411.1590	Z4545	Swirl gas cap, 4.5 mm	1
	C53-158	.11.833.101.158	V4350	Swirl gas cap, 5.0 mm	1
4	K109-160	.11.842.401.160	S3004	Nozzle cap, 0.4 mm	1
	C109-162	.11.842.401.162	S3008	Nozzle cap, 0.8 mm	1
	C109-621	.11.842.401.1621	S3018	Nozzle cap, 0.8 mm	1
5	C109-407	.11.843.021.407	S2007Y	Nozzle, 0.7 mm, 35 amp	10
	C109-408	.11.843.021.408	S2008Y	Nozzle, 0.8 mm, 50/60 amp	10
6	C109-614	.11.843.111.614	S2514Y	Nozzle, 1.4 mm, 120 amp	5
	C109-616	.11.843.111.616	S2516Y	Nozzle, 1.6 mm, 140 amp	5
	C109-618	.11.843.111.618	S2518Y	Nozzle, 1.8 mm, 160 amp	5
8	K106-253	.11.834.321.153	Z111	Gas guide cap	1
7	C106-153	.11.835.221.153	Z101	Gas guide cap, 0.4 mm	1
11	C109-510	.11.842.411.510	S042	Electrode	1
	C109-1510	.11.842.511.510	S052	Electrode	1
	K109-152	.11.842.401.152	S901	Cooling tube	5

**Hypertherm technology –
SilverLine electrodes**

Consumables – Carbon steel

	Centricut part number	Reference number	Alternate reference	Description	Pkg qty
1	C117-155	.11.833.101.155	V4335	Swirl gas cap, 3.5 mm	1
	C117-157	.11.833.101.157	V4345	Swirl gas cap, 4.5 mm	1
2	C117-081	.11.841.721.081	T502	Protection cap	1
4	C117-0271	.11.836.921.271	T522	Swirl gas nozzle	1
6	C117-163	.11.836.901.163	T3030	Nozzle cap	1
	C117-164	.11.836.901.164	T3045	Nozzle cap	1
	C117-165	.11.836.901.165	T3060	Nozzle cap	1
8	C117-015*	.11.846.921.415	T2115Y	CoolFlow™ nozzle, 1.5 mm, 120 amp	1
	C117-020*	.11.846.921.420	T2120Y	CoolFlow nozzle, 2.0 mm, 200 amp	1
	C117-025*	.11.846.921.425	T2125Y	CoolFlow nozzle, 2.5 mm, 250 amp	1
	C117-027*	.11.846.921.427	T2127Y	CoolFlow nozzle, 2.7 mm, 300 amp	1
10	C117-030*	.11.846.921.430	T2130Y	CoolFlow nozzle, 3.0 mm, 360 amp	1
	C117-153	.11.836.921.153	T101	Gas guide	1
	C117-154	.11.836.921.154	T102	Gas guide	1
	C117-542	.11.836.921.1542	T104	Gas guide	1
11	C117-1000*	.11.844.921.300	T012Y	SilverLine® electrode, O ₂ /Air	1

Consumables – Stainless steel and aluminum

	Centricut part number	Reference number	Alternate reference	Description	Pkg qty
1	C117-550	.11.833.101.1550	V4330	Swirl gas cap, 3.0 mm	1
	C117-156	.11.833.101.156	V4340	Swirl gas cap, 4.0 mm	1
	C117-157	.11.833.101.157	V4345	Swirl gas cap, 4.5 mm	1
	C53-158	.11.833.101.158	V4350	Swirl gas cap, 5.0 mm	1
5	C117-159	.11.833.101.159	V4360	Swirl gas cap, 6.0 mm	1
	C117-540	.11.846.901.1540	T4040	Swirl gas cap	1
	C117-545	.11.846.901.1545	T4045	Swirl gas cap	1
	C117-1550	.11.846.901.1550	T4050	Swirl gas cap	1
2	C117-081	.11.841.721.081	T502	Protection cap	1
3	C117-1081	.11.846.901.081	T503	Protection cap	1
4	C117-0271	.11.836.921.271	T522	Swirl gas nozzle	1
6	C117-160	.11.836.901.160	T3000	Nozzle cap	1
	C117-608	.11.846.901.1608	T3208	Nozzle cap	1
	C117-609	.11.846.901.1609	T3209	Nozzle cap	1
	C117-619	.11.846.901.1619	T3219	Nozzle cap	1
	C117-628	.11.846.901.1628	T3228	Nozzle cap	1
9	C117-623*	.11.836.911.623	T2523	CoolFlow™ nozzle, 2.3 mm, 250 amp	1
	C117-625*	.11.836.911.625	T2525	CoolFlow nozzle, 2.5 mm, 280 amp	1
	C117-627*	.11.846.911.627	T2427	CoolFlow nozzle, 2.7 mm, 360 amp	1
	C117-629*	.11.846.911.629	T2429	CoolFlow nozzle, 2.9 mm, 440 amp	1
12	C117-500	.11.836.911.500	T051	Electrode, ArH ₂	1

Maintenance Items

	Centricut part number	Reference number	Alternate reference	Description	Pkg qty
	C117-152	.11.844.901.152	T902Y	Cooling tube (carbon steel)	1
	C117-230	.11.828.911.230	V951	Cooling tube (stainless steel and aluminum)	1
	Q27055	N/A		Lubricant .25 oz. (7 ml) tube	1

*Centricut part features a unique Hypertherm design that differs from the OEM design.

**Hypertherm technology –
SilverLine electrodes and
CoolFlow™ nozzles**

Consumables – Carbon steel

	Centricut part number	Reference number	Alternate reference	Description	Pkg qty
1	C124-081	.11.848.201.081	G501	Protection cap, 20–200 amp	1
2	C124-1081	.11.848.401.081	G521	Protection cap, 280–440 amp	1
3	C124-515	.11.848.201.1515	G4015	Swirl gas cap, 20 amp	1
	C124-520	.11.848.201.1520	G4020	Swirl gas cap, 60 amp	1
	C124-525	.11.848.201.1525	G4025	Swirl gas cap, 90–130 amp	1
	C124-530	.11.848.201.1530	G4030	Swirl gas cap, 90–200 amp	1
	C124-535	.11.848.201.1535	G4035	Swirl gas cap, 200 amp, Contour Cut	1
	C124-540	.11.848.201.1540	G4040	Swirl gas cap, 200 amp, Contour Cut	1
4	C124-550	.11.848.401.1550	G4350	Swirl gas cap, 280–360 amp	1
	C124-555	.11.848.401.1555	G4355	Swirl gas cap, 360 amp	1
5	C124-604	.11.848.201.1604	G3004	Nozzle cap, 20–35 amp	1
	C124-628	.11.848.201.1628	G3028	Nozzle cap, 60–200 amp	1
	C124-649	.11.848.401.1649	G3249	Nozzle cap, 280 amp	1
6	C124-619	.11.848.401.1619	G3219	Nozzle cap, 280–360 amp	1
	C124-609	.11.848.401.1609	G3209	Nozzle cap, 360 amp	1
	C124-629	.11.848.401.1629	G3229	Nozzle cap, 360 amp	1
7	C124-406*	.11.848.221.406	G2006Y	CoolFlow™ nozzle, 25 amp	5
	C124-407*	.11.848.221.407	G2007Y	CoolFlow nozzle, 35 amp	5
	C124-408*	.11.848.221.408	G2008Y	CoolFlow nozzle, 60 amp	5
	C124-410*	.11.848.221.410	G2010Y	CoolFlow nozzle, 90 amp	5
	C124-412*	.11.848.221.412	G2012Y	CoolFlow nozzle, 130 amp	5
	C124-414*	.11.848.221.414	G2014Y	CoolFlow nozzle, 160 amp	5
8	C124-417*	.11.848.221.417	G2017Y	CoolFlow nozzle, 200 amp	5
	C124-426*	.11.848.421.426	G2326Y	CoolFlow nozzle, 280 amp	5
	C124-430*	.11.848.421.430	G2330Y	CoolFlow nozzle, 360 amp	5
9	C124-431*	.11.848.421.431	G2331Y	CoolFlow nozzle, 400 amp	5
	C124-145	.11.848.221.145	G101	Gas guide, Low amperage and Contour Cut	1
	C124-145C	.11.848.221.145C	G101C	Gas guide, 20–200 amp	1
10	C124-146	.11.848.221.146	G102	Gas guide, 60–200 amp	1
	C124-045	.11.848.421.145	G121	Gas guide, 280–400 amp	1
	C124-1000*	.11.848.221.300	G002Y	SilverLine® electrode, 20–200 amp	1
11	C124-1010*	.11.848.421.310	G032Y	SilverLine electrode, 280 amp	1
	C124-1030*	.11.848.421.330	G034Y	SilverLine electrode, 360 amp	1
	C124-142	.11.848.201.142	G901Y	Cooling tube, 20–200 amp	1
12	C124-042	.11.848.401.142	G931Y	Cooling tube, 280–400 amp	1

*Centricut part features a unique Hypertherm design that differs from the OEM design.

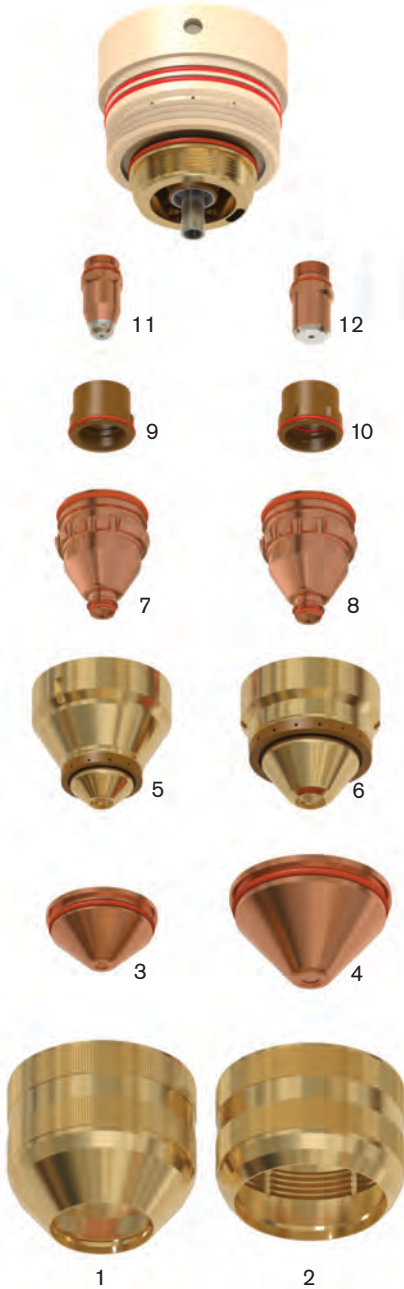

**Hypertherm technology –
SilverLine electrodes and
CoolFlow™ nozzles**

 **Centricut**[®]

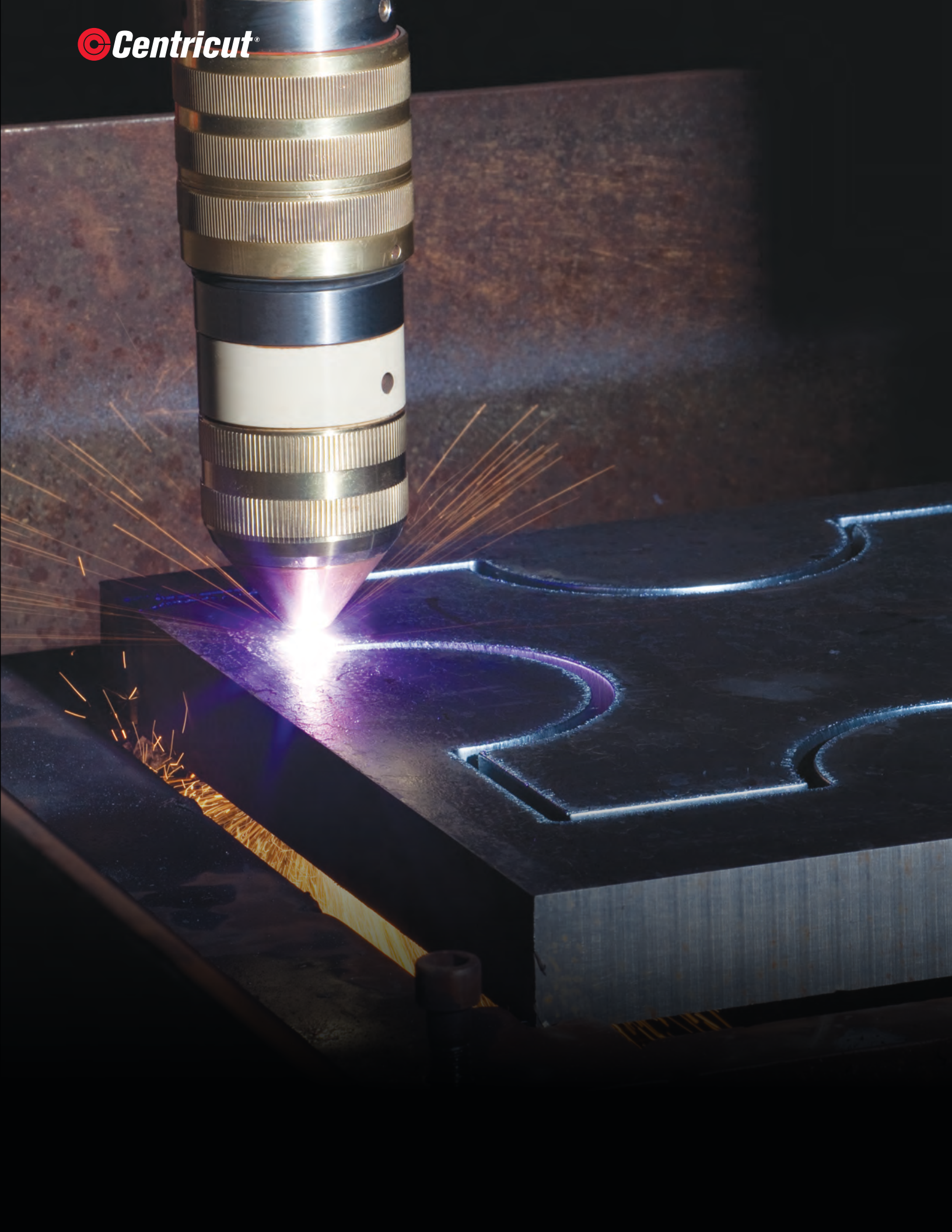

Consumables for Kjellberg® PerCut 221M and 451M torches

Centricut consumables lower your cost of cutting and deliver long life, fast cut speeds and excellent cut quality.

- Equal performance to Kjellberg Neo consumables, but at a lower price.
- Centricut consumables fit all versions of the PerCut 221M and PerCut 451M torches.
- Patented keyless nozzle design provides better performance and improved cooling around the orifice and o-ring.
- SilverLine electrodes and CoolFlow nozzles deliver exceptional cut quality and fast cutting speeds over the full life of the consumables.

Centricut keyless nozzles can be used in all PerCut 210M, 221M, 450M and 451M HiFocus torches.



Our keyless nozzle is easy to install – simply align the arrow and oval mark on the nozzle with the oval coolant outlet on the torch and press into place.

Check out our keyless nozzle installation video at www.hypertherm.com/Eznozzle



Centricut is not affiliated with the named manufacturers. Reference to machines, parts, descriptions, and model numbers are for convenience in verifying compatibility only. All parts are made by or for Centricut and are not made by the referenced manufacturers (unless expressly indicated). Centricut is a registered trademark of Hypertherm Inc. All other trademarks are the properties of their respective owners.

Consumables



	Centricut part number	Reference number	Alternate reference	Description	Pkg qty
1	C124-981	.11.852.201.081	G502	Protection cap, 20-200 amp	1
2	C124-1981	.11.852.401.081	G522	Protection cap, 280-440 amp	1
3	C124-515	.11.848.201.1515	G4015	Swirl gas cap, 20 amp	1
	C124-520	.11.848.201.1520	G4020	Swirl gas cap, 60 amp	1
	C124-525	.11.848.201.1525	G4025	Swirl gas cap, 90-130 amp	1
	C124-530	.11.848.201.1530	G4030	Swirl gas cap, 90-200 amp	1
	C124-535	.11.848.201.1535	G4035	Swirl gas cap, 200 amp, Contour Cut	1
	C124-540	.11.848.201.1540	G4040	Swirl gas cap, 200 amp, Contour Cut	1
4	C124-550	.11.848.401.1550	G4350	Swirl gas cap, 280-360 amp	1
	C124-555	.11.848.401.1555	G4355	Swirl gas cap, 360 amp	1
5	C124-604	.11.848.201.1604	G3004	Nozzle cap, 20-35 amp	1
	C124-628	.11.848.201.1628	G3028	Nozzle cap, 60-200 amp	1
6	C124-649	.11.848.401.1649	G3249	Nozzle cap, 280 amp	1
	C124-609	.11.848.401.1609	G3209	Nozzle cap, 360 amp	1
7	C124-402*	.11.848.221.406	G2006Y	CoolFlow™ nozzle, 25 amp	5
	C124-407*	.11.848.221.407	G2007Y	CoolFlow nozzle, 35 amp	5
	C124-408*	.11.848.221.408	G2008Y	CoolFlow nozzle, 60 amp	5
	C124-410*	.11.848.221.410	G2010Y	CoolFlow nozzle, 90 amp	5
	C124-412*	.11.848.221.412	G2012Y	CoolFlow nozzle, 130 amp	5
	C124-414*	.11.848.221.414	G2014Y	CoolFlow nozzle, 160 amp	5
8	C124-417*	.11.848.221.417	G2017Y	CoolFlow nozzle, 200 amp	5
	C124-426*	.11.848.421.426	G2326Y	CoolFlow nozzle, 280 amp	5
9	C124-430*	.11.848.421.430	G2330Y	CoolFlow nozzle, 360 amp	5
	C124-431*	.11.848.421.431	G2331Y	CoolFlow nozzle, 400 amp	5
9	C124-145C	.11.848.221.145C	G101C	Gas guide, 20-200 amp	1
10	C124-045	.11.848.421.145	G121	Gas guide, 280-400 amp	1
11	C124-1020*	.11.848.231.320	G011Y	SilverLine® electrode, 20-60 amp	1
	C124-1050*	.11.848.231.350	G015Y	SilverLine electrode, 90-160 amp	1
12	C124-1060*	.11.848.231.360	G016Y	SilverLine electrode, 200 amp	1
	C124-1310*	.11.848.401.310	G092Y	SilverLine electrode, 280 amp	1
	C124-1030*	.11.848.421.330	G034Y	SilverLine electrode, 360 amp	1
	C124-1142	.11.852.201.142	G902Y	Cooling tube, 20-200 amp	1
	C124-042	.11.848.401.142	G931Y	Cooling tube, 280-400 amp	1

*Centricut part features a unique Hypertherm design that differs from the OEM design.

**Hypertherm technology –
SilverLine electrodes and
CoolFlow™ nozzles**

Enhancements for Kjellberg® PB-S80 torch

Centricut consumables lower your cost of cutting without sacrificing cut quality or productivity.

- 25% longer consumable life compared to Kjellberg Yellow XLife on mild steel
- Speed and cut quality equal to Kjellberg
- High quality parts – set to set consistency
- Full product line featuring consumables for both mild steel and stainless steel cutting

Consumable life with ISO 9013.2002(E) cut quality ranges noted

250 A cutting of 19 mm mild steel

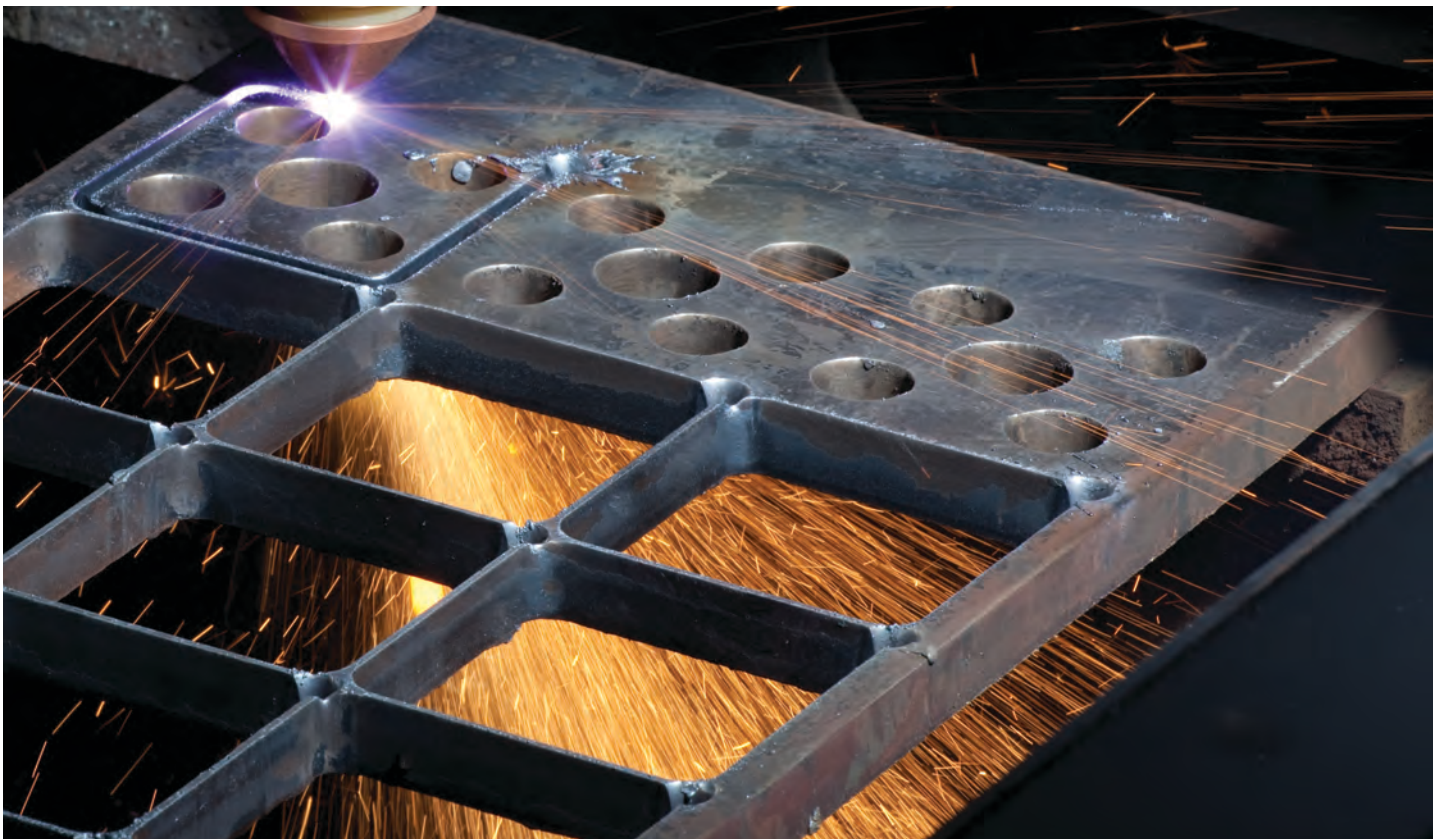
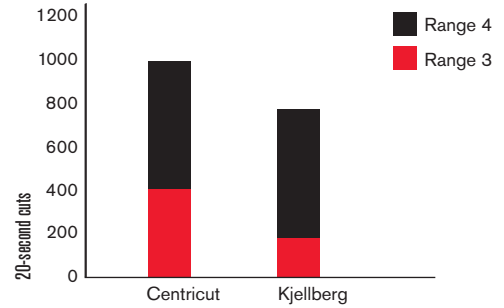

Centricut is not affiliated with the named manufacturers. Reference to machines, parts, descriptions, and model numbers are for convenience in verifying compatibility only. All parts are made by or for Centricut and are not made by the referenced manufacturers (unless expressly indicated). Centricut is a registered trademark of Hypertherm Inc. All other trademarks are the properties of their respective owners.

Consumables – Carbon Steel (O₂)

	Centricut part number	Reference number	Alternate reference	Description	Pkg qty
1	C117-155	.11.833.101.155	V4335	Swirl gas cap, 3.5 mm	1
	C117-157	.11.833.101.157	V4345	Swirl gas cap, 4.5 mm	1
2	C53-261	.11.833.101.261	V501	Protective cap	1
	C117-261	.11.833.121.261	V502	Protective cap	1
3	C117-271	.11.836.901.271	T521	Swirl gas nozzle	1
	C117-0271	.11.836.921.271	T522	Swirl gas nozzle	1
	C117-1271	.11.833.121.271	V522	Swirl gas nozzle	1
5	C117-163	.11.836.901.163	T3030	Nozzle cap	1
	C117-164	.11.836.901.164	T3045	Nozzle cap	1
	C117-165	.11.836.901.165	T3060	Nozzle cap	1
7	C117-015*	.11.846.921.415	T2115Y	CoolFlow™ nozzle, 1.5 mm, 120 amp	1
	C117-020*	.11.846.921.420	T2120Y	CoolFlow nozzle, 2.0 mm, 200 amp	1
	C117-025*	.11.846.921.425	T2125Y	CoolFlow nozzle, 2.5 mm, 250 amp	1
	C117-027*	.11.846.921.427	T2127Y	CoolFlow nozzle, 2.7 mm, 300 amp	1
	C117-030*	.11.846.921.430	T2130Y	CoolFlow nozzle, 3.0 mm, 360 amp	1
9	C117-153	.11.836.921.153	T101	Gas guide	1
	C117-154	.11.836.921.154	T102	Gas guide	1
	C117-542	.11.836.921.1542	T104	Gas guide	1
10	C117-1000*	.11.844.921.300	T012Y	SilverLine® electrode	1
	C117-152	.11.844.901.152	T902Y	Water tube	1

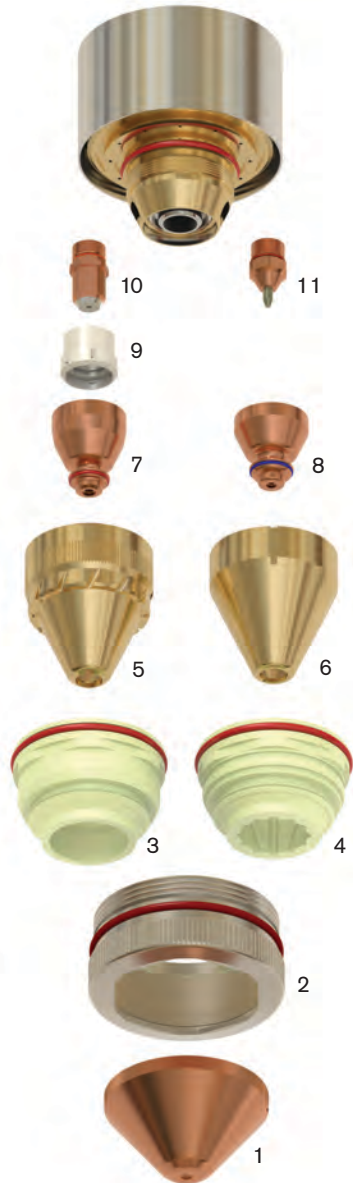

**Hypertherm technology –
SilverLine electrodes and
CoolFlow™ nozzles**

Consumables – Carbon Steel/Stainless Steel (Air)

	Centricut part number	Reference number	Alternate reference	Description	Pkg qty
1	C53-158	.11.833.101.158	V4350	Swirl gas cap, 5.0	1
2	C117-261	.11.833.121.261	V502	Protective cap	1
	C117-081	.11.841.721.081	T502	Protective cap	1
4	C117-1271	.11.833.121.271	V522	Swirl gas nozzle	1
6	C53-790	.12.37790	V3000	Nozzle cap	1
	C53-850	.12.40850	L2	Nozzle, 250 amp	5
	C53-860	.12.40860	V101	Gas guide	5
	C53-870	.12.40870	K2	Electrode, Air	5
	K53-440	.12.51440	V931	Cooling tube, PB-S75, Air	5

Consumables – Stainless Steel/Aluminum (ArH₂N₂)

	Centricut part number	Reference number	Alternate reference	Description	Pkg qty
1	C117-550	.11.833.101.1550	V4330	Swirl gas cap, 3.0 mm	1
	C117-155	.11.833.101.155	V4335	Swirl gas cap, 3.5 mm	1
	C117-156	.11.833.101.156	V4340	Swirl gas cap, 4.0 mm	1
	C117-157	.11.833.101.157	V4345	Swirl gas cap, 4.5 mm	1
	C53-158	.11.833.101.158	V4350	Swirl gas cap, 5.0 mm	1
	C117-159	.11.833.101.159	V4360	Swirl gas cap, 6.0 mm	1
2	C117-261	.11.833.121.261	V502	Protective cap	1
	C117-081	.11.841.721.081	T502	Protective cap	1
4	C117-1271	.11.833.121.271	V522	Swirl gas nozzle	1
6	C53-790	.12.37790	V3000	Nozzle cap	1
8	C117-780*	.12.37780	A1	CoolFlow™ nozzle, 1.5 mm, 120 amp, ArH ₂	1
	C117-620*	.11.828.511.620	A3	CoolFlow nozzle, 2.0 mm, 180 amp, ArH ₂	1
	C117-910*	.12.40910	A2	CoolFlow nozzle, 2.3 mm, 300 amp, ArH ₂	1
11	C117-0550	.11.828.911.550	K5	Electrode, ArH ₂	1
	C117-230	.11.828.911.230	V951	Cooling tube	1

Maintenance Items

	Centricut part number	Reference number	Alternate reference	Description	Pkg qty
	027055	N/A		O-ring lube	1

*Centricut part features a unique Hypertherm design that differs from the OEM design.

Centricut is not affiliated with the named manufacturers. Reference to machines, parts, descriptions, and model numbers are for convenience in verifying compatibility only. All parts are made by or for Centricut and are not made by the referenced manufacturers (unless expressly indicated). Centricut is a registered trademark of Hypertherm Inc. All other trademarks are the properties of their respective owners.

Consumables

	Centricut part number	Reference number	Alternate reference	Description	Pkg qty
1	C53-158	.11.833.101.158	V4350	Swirl gas cap, 5.0 mm	1
2	C53-261	.11.833.101.261	V501	Protection cap	1
	K53-160	.11.828.701.160		Protection cap, PB-S75	10
3	K53-271	.11.833.101.271	V521	Swirl gas nozzle	10
4	C53-790	.12.37790	V3000	Nozzle cap	1
5	C53-920*	.11.828.901.420	L1-XL	CoolFlow™ nozzle, 160 amp	1
	C53-925*	.11.828.901.425	L2-XL	CoolFlow nozzle, 250 amp	1
	C53-927*	.11.828.901.427	L4-XL	CoolFlow nozzle, 300 amp	1
	C53-050	.12.43050	L1	Nozzle, 160 amp, Air	5
	C53-850	.12.40850	L2	Nozzle, 250 amp, Air	5
6	C117-780*	.12.37780	A1	CoolFlow, nozzle, 1.5 mm, 120 amp, ArH ₂	1
	C117-620*	.11.828.511.620	A3	CoolFlow, nozzle, 2.0 mm, 180 amp, ArH ₂	1
	C117-910*	.12.40910	A2	CoolFlow, nozzle, 2.3 mm, 300 amp, ArH ₂	1
7	C53-860	.12.40860	V101	Gas guide	1
8	C53-1000*	.11.828.921.300	K2-XL	SilverLine® electrode, O ₂	1
	C53-870	.12.40870	K2	Electrode, Air	5
9	C117-0550	.11.828.911.550	K5	Electrode, ArH ₂	1

Maintenance items

	Centricut part number	Reference number	Alternate reference	Description	Pkg qty
	K53-923	.10.505.923		O-ring, nozzle cap/torch seal, 28x2 mm	10
	K53-908	.10.505.908		O-ring, nozzle/torch, 18x2 mm	10
10	C117-230	.11.828.911.230	V951	Cooling tube PB-S75 ArH ₂	1
	K53-440	.12.51440	V931	Cooling tube, PB-S75, Air	5
	C23-001	N/A		Removal tool, swirl ring	1
	027055			Lubricant .25 oz. (7 ml) tube	1

*Centricut part features a unique Hypertherm design that differs from the OEM design.

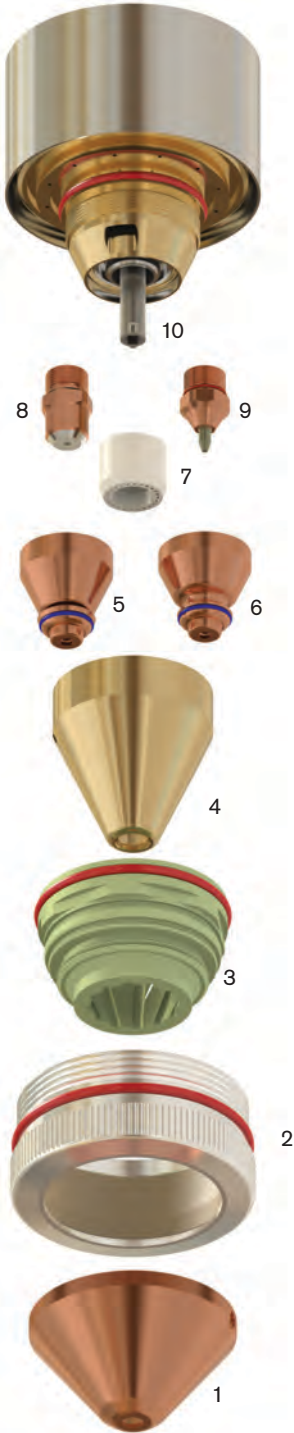

**Hypertherm technology –
SilverLine electrodes and
CoolFlow™ nozzles**

System: Super-400 Plus®

Consumables

	Centricut part number	Reference number	Description	Pkg qty
1	C121-503	40020503	Protection cap	1
2	C121-366	40016366	Shield	1
3	C121-359*	40016359	CoolFlow™ nozzle, 1.7R	1
	C121-362*	40016362	CoolFlow nozzle, 1.7L	1
	C121-360*	40016360	CoolFlow nozzle, 2.3R	1
	C121-363*	40016363	CoolFlow nozzle, 2.3L	1
	C121-233*	40017233	CoolFlow nozzle, 2.9R	1
	C121-234*	40017234	CoolFlow nozzle, 2.9L	1
4	C121-899	40001899	Swirl ring, R	1
	C121-567	40004567	Swirl ring, L	1
5	C121-1058*	40016358	SilverLine® electrode	1

Maintenance items

	Centricut part number	Reference number	Description	Pkg qty
	027055	N/A	Lubricant .25 oz. (7 ml) tube	1

*Centricut part features a unique Hypertherm design that differs from the OEM design.

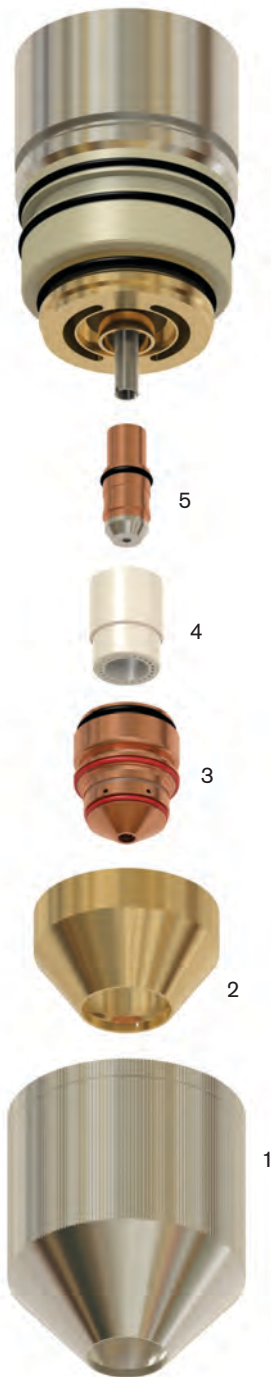

**Hypertherm technology –
 SilverLine electrodes and
 CoolFlow™ nozzles**

Consumables

	Centricut part number	Reference number	Description	Pkg qty
1	C33-008	65-0432-001	Cap #1	1
2	C33-140*	65-0432-003	CoolFlow™ nozzle, O ₂ , 0.4 mm	5
	C33-130*	65-0432-002	CoolFlow nozzle, O ₂ , 0.6 mm	5
	C33-160*	65-0432-013	CoolFlow nozzle, O ₂ , 0.7 mm	5
3	C33-006	65-0432-006	Swirler, standard, CCW	1
	C33-066	65-0432-066	Swirler, reverse, CW	1
4	C33-021	65-0432-021	Ceramic guide	1
5	C33-930	65-0432-005	Electrode with o-ring	5

Maintenance items

	Centricut part number	Reference number	Description	Pkg qty
	C33-007	65-0432-007	O-ring kit	3
	K33-010	969-94-41010	Razor 40 torch body	1
	K33-420	65-0432-020	Razor 40 torch body with 1.8 mm leads	1
	027055	N/A	Lubricant .25 oz. (7 ml) tube	1

*Centricut part features a unique Hypertherm design that differs from the OEM design.



**Hypertherm technology –
CoolFlow™ nozzles**

Consumables

	Centricut part number	Reference number	Description	Pkg qty
1	C35-016	65-0434-016	Cap #2	1
2	C35-019	65-0434-019	Shield cap, 90 amp	1
	C35-905	65-0442-005	Shield cap, 120 amp	1
	C35-004	65-0438-004	Shield cap, quicksilver	1
3	C35-540	65-0434-022	Spacer ring, 90 amp	1
4	C35-250	65-0442-004	Spacer ring, 120 amp	1
5	C35-015	65-0434-015	Cap #1	1
	C35-020	65-0438-005	Cap #2, quicksilver	1
6	C35-160*	65-0434-017	CoolFlow™ nozzle, O ₂ , 0.8 mm	5
	C35-180*	65-0434-007	CoolFlow nozzle, O ₂ , 1.1 mm	5
	C35-002*	65-0442-002	CoolFlow nozzle, O ₂ , 1.3 mm	5
	C35-8002*	65-0438-002	CoolFlow nozzle, "S", 0.8 mm, quicksilver	5
	C35-8003*	65-0438-003	CoolFlow nozzle, "S", 1.1 mm, quicksilver	5
7	C35-018	65-0434-018	Swirler, 90 amp, CCW	1
	C35-003	65-0442-003	Swirler, 120 amp, CW	1
8	C35-350	65-0434-020	Ceramic guide with o-ring	1
9	C35-1020*	65-0442-001	SilverLine® electrode, 90-120 amp	1

Maintenance items

	Centricut part number	Reference number	Description	Pkg qty
10	C35-110	65-0442-009	Cooling tube, 90/120 amp	1
	K35-021	65-0434-021	O-ring kit	1
	K35-006	65-0442-006	Razor 90/120 torch body without o-rings	1
	027055	N/A	Lubricant .25 oz. (7 ml) tube	1

*Centricut part features a unique Hypertherm design that differs from the OEM design.

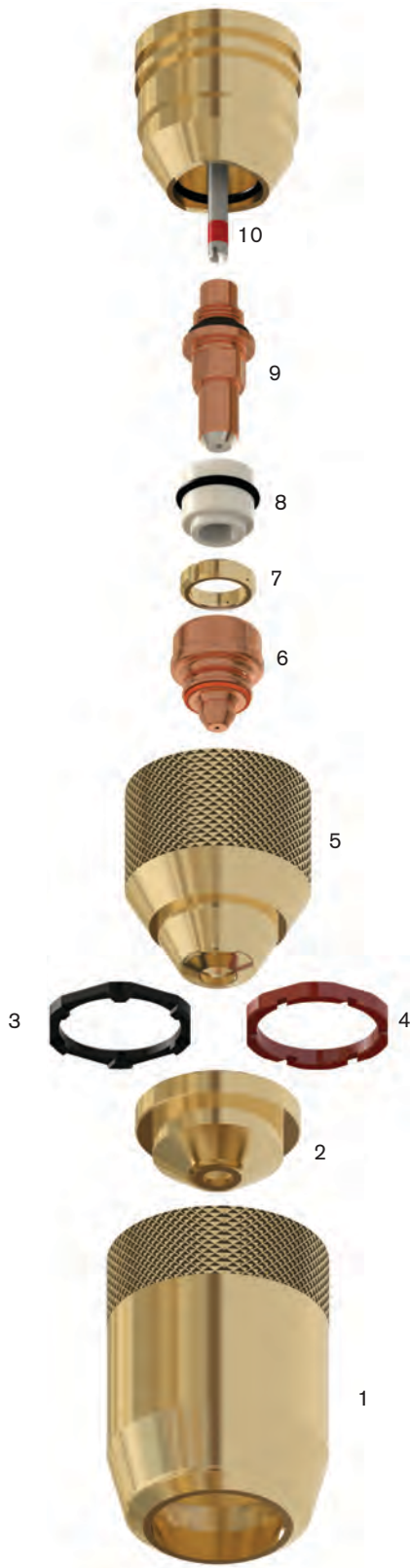

**Hypertherm technology –
SilverLine electrodes and
CoolFlow™ nozzles**

Consumables

	Centricut part number	Reference number	Description	Pkg qty
1	T30-790	9-5790	Shield cup, copper	1
2	C30-748	9-5748	Tip, Air, .043, 50 amp	5
	C30-747	9-5747	Tip, Air, .055, 100 amp	5
	C30-746	9-5746	Tip, Air, .070, 150 amp	5
	C30-766	9-5766	Tip, N2, .052, 100 amp	5
	C30-767	9-5767	Tip, N2, .067, 150 amp	5
	C30-751	9-5751	Tip, O2, .070, 150 amp	5
3	C30-749	9-5749	Electrode, Air	5
	C30-760	9-5760	Electrode, O ₂	5

Maintenance items

	Centricut part number	Reference number	Description	Pkg qty
	C30-M33	N/A	Liner, replacement	1
	027055	N/A	Lubricant .25 oz. (7 ml) tube	1

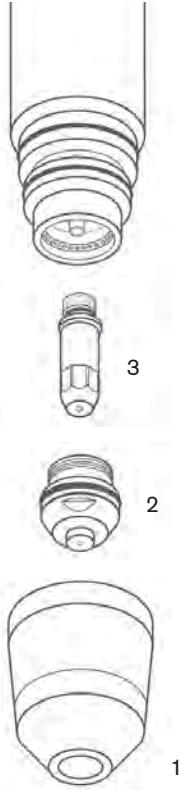

Consumables

	Centricut part number	Reference number	Description	Pkg qty
1	C55-803	20-1003	Shield, 50 amp	1
	C55-804	20-1004	Shield, 100-225 amp	1
	C55-805	20-1005	Shield, 300 amp	1
	C55-006	20-1006	Shield, 100-300 amp, underwater	1
	T55-028	20-1028	Shield, 100-300 amp, underwater	1
2	C55-002	20-1002	Shield, cup body	1
	T55-029	20-1029	Shield, cup body, underwater	1
3	C55-030	20-1030	Tip, 50 amp	1
	C55-031	20-1031	Tip, 100 amp	1
	C55-032	20-1032	Tip, 150 amp	1
	C55-033	20-1033	Tip, 225 amp	1
	C55-034	20-1034	Tip, 300 amp	1
4	C55-008	20-0008	Gas distributor, 50-225 amp	1
	T55-009	20-1009	Gas distributor, 300 amp	1
5	C55-710	20-1016, 20-1010, 20-1021	CopperLine® electrode, Air/O ₂ , 50-300 amp	1
	C55-718	20-1015, 20-1018	CopperLine electrode, Air/O ₂ , 50-300 amp	1
	T55-025	20-1025	Electrode, ArH ₂ , 100-300 amp	5

Maintenance items

	Centricut part number	Reference number	Description	Pkg qty
6	T55-410	9-6410	Maximizer 300 torch body	1
	C55-050	N/A	O-ring	5
	027055	N/A	Lubricant .25 oz. (7 ml) tube	1



Technical support

- Our product specialist team can answer questions about any plasma cutting system. Whether it's a question about a part, system, or for guidance on how to optimize performance, our experts can help.
- We stand behind our products with industry-leading technical expertise
- OEM-qualified product specialists on staff with over 30 years experience.



**HELPING YOU
SHAPE THE WORLD.**



PLASMA | LASER | WATERJET | AUTOMATION | SOFTWARE | CONSUMABLES

For more information on Centricut products, visit
www.hypertherm.com/centricutplasma

Hypertherm, Centricut, SilverLine and CoolFlow are trademarks of Hypertherm Inc., and may be registered in the United States and/or other countries. All other trademarks are the property of their respective owners.

Environmental stewardship is one of Hypertherm's core values, and it is critical to our success and our customers' success. We are striving to reduce the environmental impact of everything we do. For more information: www.hypertherm.com/environment.

© 10/2017 Hypertherm Inc. Revision 5
880470



Hypertherm[®]
SHAPING POSSIBILITY™

